

FALL 2014

# *One Voice* for Hygienic Equipment Design for Low-Moisture Foods



brought to you by:

PMMI | 11911 Freedom Drive, Suite 600 | Reston, VA 20190



The Association for Packaging and Processing Technologies



Leadership Network  
Moving Operational Excellence Forward



**PURPOSE**

The purpose of this document is to utilize existing industry standards, guidelines and information to define a process that will allow consumer packaged goods (CPGs) and original equipment manufacturers (OEMs) to reach consensus of design criteria for hygienic equipment for **low-moisture food manufacturing**.

This document was developed through a collaboration of CPGs & OEMs resulting in ONE VOICE® for the industry.

**The document has two parts:**

- Part 1 describes the Joint Collaboration Process
- Part 2 Criteria for the Design and Construction of Equipment Used to Manufacturer Low-moisture Foods.

Part 2 represents the design criteria and information from several industry resources that was coalesced into a “what is important and how to achieve the basic hygienic design needs” tool.

**Part 2 is divided into five major sections:**

- General
- Materials of Construction
- Informative References
- Design and Construction
- Definitions

Along with the text, it has graphic examples of hygienic designs to assist in the construction and fabrication of equipment.

**SPONSORS**



Facilitated by PMMI, the OpX Leadership Network is a dynamic community of manufacturing, engineering and operations professionals dedicated to operational excellence. Through open dialogue between CPG manufacturers and OEMs, the OpX Leadership Network provides an exceptional forum where the best minds come together to identify and solve common operational challenges, and apply best practices and innovative solutions to the real-world context of manufacturing.



PMMI is a trade association of more than 600 member companies that manufacture packaging, processing and related converting machinery in the United States or Canada; machinery components and packaging containers and materials. PMMI’s vision is to be the leading global resource for the packaging and processing supply chain, and its mission is to improve and promote members’ abilities to meet the needs of their customers. Learn more about PMMI and the PACK EXPO trade shows at PMMI.org and Packexpo.com.



The NSF provides auditing, education and risk management solutions for public health and the environment. With a mission to protect and improve global human health they are an independent, accredited organization that develops standards, tests and certifying products and systems. NSF follows the American National Standards Institute (ANSI) standards development process.



GE is transforming the way companies do business with high-performance technology solutions powered by the Industrial Internet. We provide customers across various industries with industrial software, control systems and embedded computing platforms — enabling them to connect their machines, data, and insights, and people to optimize their assets and operations. The results: greater productivity, reduced unplanned downtime, and lower costs.

**PROJECT TEAM MEMBERS – OpX LEADERSHIP NETWORK:**

- Madinah Allen . . . . . Snyder’s-Lance
- Trisha Araujo . . . . . ConAgra Foods
- Jeffrey Barach . . . . . Barach Enterprises, LLC
- Steve Blackowiak . . . . . Buhler Group
- Randy Cotton . . . . . Big Heart Pet Brands
- Lee DeBeau . . . . . formerly Schwans Foods
- David Drum . . . . . Kellogg
- Tom Egan . . . . . PMMI
- Jessica Evans . . . . . NSF
- Shane Guimbellot . . . . . MOM Brands
- Robert Hagberg . . . . . Land O’Lakes
- Jim Halliday . . . . . PTL
- Fred Hayes . . . . . PMMI
- David Heutmaker . . . . . MOM Brands
- John Keenan . . . . . Post Foods
- Glen Long . . . . . ADCO Manufacturing
- James Mino . . . . . Hormel
- Gary Moore . . . . . Hillshire Brands
- Eric Ney . . . . . Big Heart Pet Brands
- Stephen Perry . . . . . OpX Leadership Network
- Bob Risley . . . . . Intralox
- Stephen Schlegel . . . . . OpX Leadership Network
- Mike Scouten . . . . . Hosokawa Bepex
- Joe Shebuski . . . . . Cargill
- John Spengler . . . . . GE
- Bill Sutton . . . . . Kollmorgen
- Matt Swanson . . . . . Campbell Soup

**CONTENTS**

Purpose . . . . . 2

**PART 1 - A CPG & OEM JOINT COLLABORATION PROCESS**

0 - Executive Summary . . . . . 5

1 - Joint Collaboration Process (JCP) . . . . . 5

2 - Assess the Risk – Step 1 . . . . . 7

3 – Facility Hygienic Zoning . . . . . 9

4 - Cleaning Methods . . . . . 10

5 - Determine the Hygienic Zones and Cleaning Methods - Step 2 . . . . . 11

6 - Utilize the Tools - Step 3 . . . . . 12

7 - Have Discussions between CPG & OEM - Step 4 . . . . . 12

Annex A – Tools and References . . . . . 13

**PART 2 - CRITERIA FOR THE DESIGN AND CONSTRUCTION OF EQUIPMENT USED TO MANUFACTURE LOW-MOISTURE**

Foods . . . . . 16

Harmonization . . . . . 16

Format of Part 2 . . . . . 16

1 General . . . . . 16

2 Informative references . . . . . 17

3 Definitions . . . . . 17

4 Materials of construction . . . . . 19

    4.1 GENERAL . . . . . 19

    4.2 PRODUCT CONTACT SURFACES . . . . . 20

    4.3 NON-PRODUCT CONTACT SURFACES . . . . . 22

5 Design and construction . . . . . 23

    5.1 PRODUCT CONTACT SURFACES . . . . . 23

    5.2 NON-PRODUCT CONTACT SURFACES . . . . . 27

Annex B Examples from NSF/ANSI/3A 14159-1 . . . . . 34

# PART



A CPG & OEM  
joint collaboration  
process

## 0 EXECUTIVE SUMMARY

Low-moisture Consumer Packaged Goods (CPG) food producers have a goal of using equipment to minimize risk of food contamination. The Original Equipment Manufacturer (OEM) supplying this equipment have a goal of building that equipment in a competitive environment, offering a streamlined number of options that are profitable.

### Definitions

- **Low Moisture Foods** - edible food products that have a water activity (a<sub>W</sub>) generally less than 0.85.
- **Product** - in this document includes raw ingredients and finished low moisture food products.

Food Safety Modernization Act (FSMA) has increased the regulation of many factors that impact both design and operation of such equipment.

Utilizing existing resources, in 2013 the Engineering Solutions Group in PMMI's OpX Leadership Network initiated this project to address issues and enable CPGs & OEMs to speak with **One Voice**.

Design criteria and information from several of these industry resources was distilled into a 4-step method that will allow a CPG & OEM to use 1) risk assessment, with 2) hygienic zone information, with 3) existing standards and checklists, to produce 4) discussion and consensus of design criteria based on use and unique needs.

What follows here is a CPG & OEM Joint Collaboration Process (JCP) describing each of these steps.

## 1 JOINT COLLABORATION PROCESS (JCP)

FIGURE 1: THE JCP STEPS

1.

### Assess the Risk

Evaluate biological, chemical, and physical hazards.

Is wet clean or dry clean required?

2.

### Determine the Hygienic Zones & Cleaning Methods

How the equipment is to be used and what hygienic zones level is required for sanitary operations.

How is the equipment cleaned - wet or dry?

What type of product contact surfaces?

3.

### Utilize the Tools

Use the decision tree to identify the hygienic design criteria.

Use TR3 Part 2 for design criteria.

4.

### Have Discussions Between CPG & OEM

Use the criteria to discuss and identify the required and appropriate hygienic design specifications to reach an agreement on equipment design.

This JCP is based on the iterative process of risk assessment (see ANSI/PMMI B155.1-2011 Safety Requirements for Packaging Machinery and Packaging-Related Converting Machinery). The goal is for discussion and a consensus approach to meet the purchasing goals of both a CPG and OEM.

The JCP approach presented here is a way to streamline the activities of developing basic design specifications and criteria to move the conversation from a “blank page” situation to a “common criteria” level. In that manner, and with agreement on general design criteria, the goal of reaching a common consensus on the basic criteria needed to satisfy current and future equipment hygienic design criteria can be met more easily and efficiently. A JCP can convey a pathway describing what a majority of the industry (CPGs and OEMs) have

indicated are the most important criteria and how to go about using this information to reach a negotiated contract resulting in a Factory Acceptance Test (FAT) and Site Acceptance Test (SAT) achieved more easily. Following a JCP approach can guide development of equipment specifications and further provide ongoing industry partnership efforts to improve food safety outcomes by adopting proven hygienic design strategies and addressing continuous structural design advances.

Once the basic design criteria are identified, discussions and negotiations can proceed to address individual or unique specifications beyond the essential base level needs. To assist in the understanding of the four step process, Figure 1 gives a graphic representation of the steps involved in the JCP approach. Each is described in more detail below.

**WHY HAVE A JCP?**

**Identify & Agree...**

...on the minimum requirements for equipment to meet food safe design for manufacture of low-moisture foods



**Within** and **Between**, **Early** and **Often**

**Increase collaboration between + feedback from**

Quality, Operations, Sanitation, Engineering, and the Shop Floor

**KISS**

Make existing knowledge, guidelines, standards **easier** to apply in fabrication and manufacturing

**HOW THE JCP CAN HELP**

**Best Value Options:  
Balance Capital with risk**

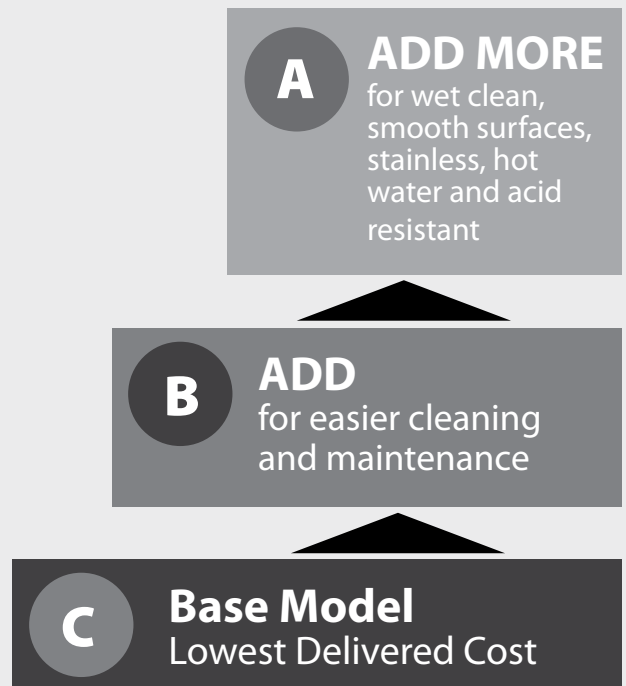

## ASSESS THE RISK – STEP 1

The iterative process of risk assessment is an essential tool in the manufacture, packaging and distribution of safe food products. The process shown in Figure 2 from ANSI/PMMI B155.1-2011, has eight steps:

1. Define the scope of the assessment
2. Identify the hazards
3. Evaluate the risk
4. Reduce risk by applying reduction methods
5. Evaluate the risk
6. Determine if acceptable risk has been achieved
7. Validate the risk reduction measures
8. Document the results

The CPG would use the risk assessment process to determine what the potential hazards are and how to protect the product from relevant hazards. These hazards are generally assigned into one of three categories:

- Biological risks are predominately from foodborne pathogens such as Salmonella species, Pathogenic E. coli and Listeria.
- Chemical risks include injury coming from chemical sanitizers, lubricants and especially those risks associated with allergens.
- Physical risk can be derived from metal, plastic, cloth, etc. coming from equipment sources that lead to intestinal tract, dental or choking injuries.

A risk assessment example generated with PackSafe® software is shown in Figure 3.

Next the CPG would use the risk assessment process to determine what facility hygienic zones are required in the manufacturing process and the level of hygienic design that is required for the equipment that will be located in the facility hygienic zones. The CPG may choose to balance a combination of equipment design specifications and internal controls (cleaning methods, frequency of cleaning, etc.) to achieve an acceptable level of risk.

Once the hygienic design criteria for equipment are identified the CPG can include the specifications in the procurement documents for equipment. The OEM then knows what design criteria should be met. The OEM should use the risk assessment process to apply the design criteria contained in B155 TR3 Part 2 to reduce the risk of product contamination to a level specified in the procurement specifications.

**FIGURE 2**  
ITERATIVE PROCESS OF RISK ASSESSMENT

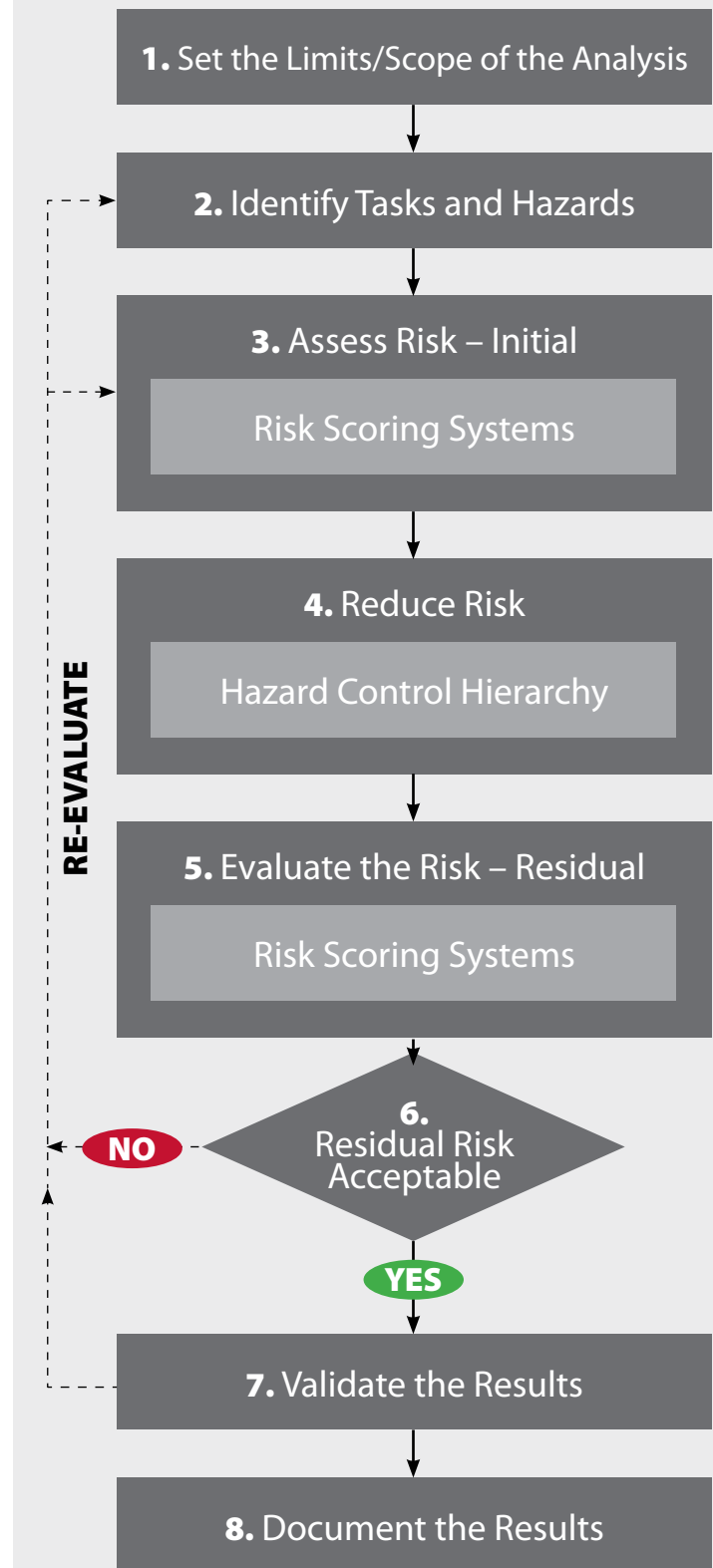

**FIGURE 3**  
**SAMPLE PRELIMINARY RISK ASSESSMENT**

**designsafe Report**

**Application:** Snack food  
**Description:** Snack food manufactured using fryers but seasoned after the kill step before primary packaging  
**Product Identifier:** Multiple head weigher and vertical form fill seal bagger  
**Assessment Type:** Preliminary  
**Sources:** PMMI B155.1 TR3 design guidelines for low moisture foods  
**Risk Scoring System:** ANSI B11.0 (TR3) Two Factor  
**Guide sentence:** When doing [task], the [user] could be injured by the [hazard] due to the [failure mode].

**Analyst Name(s):**  
**Company:** xxxx  
**Facility Location:** High Hygiene dry clean area of the plant  
**Limits:**

Item ID	User/Task	Hazard/Failure Mode	Initial Assessment Severity Probability	Risk Level	Risk Reduction Methods/Control System	Final Assessment Severity Probability	Risk Level	Status Responsible/ Comments/ Reference
1-1-1	All Users General Public	Food Safety - Biological: Microorganisms (relevant) Bacteria, fungi, yeasts, molds, spores, and viruses that are able to contaminate, multiply, or survive in a product and are able to be harmful. Microorganisms are part of the ingredient that arrive at the facility	Catastrophic Likely	High	Kill step in processing	Catastrophic Remote	Low	
1-1-2	All Users General Public	Food Safety - Biological: Bacterial Possible introduction in High Hygiene area	Catastrophic Unlikely	Medium	Dry Clean to a microbiological level, Equipment designed to B155.1 - TR3 High Hygiene dry clean	Catastrophic Remote	Low	
1-1-3	All Users General Public	Food Safety - Chemical: Cleaning compounds Improper use of chemicals during handling, cleaning	Serious Unlikely	Medium	standard procedures, restricted users, warning label(s), warning sign(s), special procedures, gloves, special clothing, safety glasses, respiratory protection	Serious Remote	Low	
1-1-4	All Users General Public	Food Safety - Chemical: Allergens Cross contamination between products	Serious Likely	High	Dry Clean to a microbiological level, Equipment designed to B155.1 - TR3 High Hygiene dry clean	Serious Remote	Low	
1-1-5	All Users General Public	Food Safety - Physical: Any unwanted matter Unwanted matter introduced into the product thru production	Serious Unlikely	Medium	X-ray or metal detection system after the product is in the primary package	Serious Remote	Low	

## 3 FACILITY HYGIENIC ZONING

Each food manufacturing operation requires an appropriate environmental cleanliness level in order to minimize risks of contamination. The degree of the hygienic design of the equipment in the facility depends on the product and a thorough analysis of its potential hazards. It is important to locate where (what zone) in the facility the equipment will be operating and what level of hygiene is appropriate based on the results of a risk assessment.

**FIGURE 4: FACILITY HYGIENIC ZONE MAP**

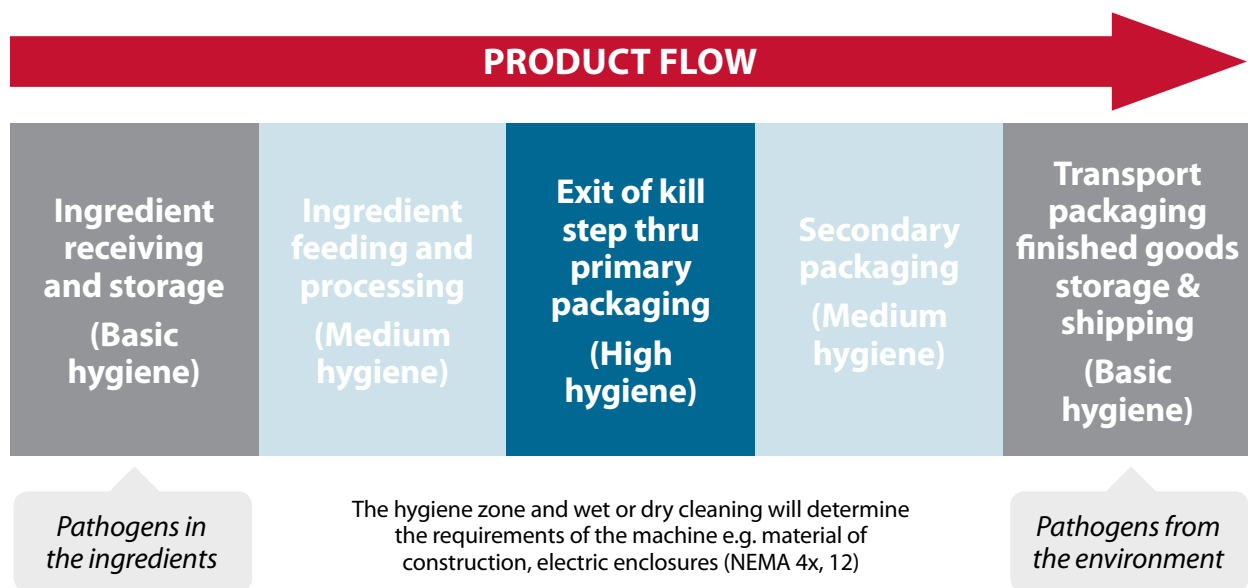

### Use the Facility Zone Mapping to Prevent Contamination and Identify the Appropriate Equipment Hygiene Level

The fabrication techniques for the production equipment may vary accordingly to the level of hygiene and method of cleaning required to minimize or prevent the identified hazards. The following are descriptions of the two distinct hygienic levels (based on zones) selected for this JCP. Some in the industry assign four or more zones to their operations; however, after

careful analysis of the applications involving low-moisture equipment and the locations of this equipment in facilities and processing operations, it was determined that most equipment would fall into two distinct zones - Basic and High Hygiene. **An Equipment Medium Hygiene level was considered early on, but the design criteria were so similar to those of High Hygiene, it was combined with the High Hygiene group.**<sup>2</sup>

<sup>1</sup> The document is intended to cover all phases of the low moisture food manufacturing process from receiving and storing ingredients thru warehousing of packaged goods. Additional information –

PRODUCT SAFETY SOLUTIONS GROUP - Validating the Reduction of Salmonella and Other Pathogens in Heat Processed Low-Moisture Foods Appendix Table 1 & Table 2

<sup>2</sup> The concept of basic, medium and high is accepted for zoning. However from an equipment design view the equipment design criteria basis wet and dry, high wet and dry give enough granularity... fewer variables are desirable from an equipment manufacturing view.

See also - European Hygienic Engineering Design Group (EHEDG) Glossary 2013/12.G03 - [http://ehedg.org/uploads/EHEDG\\_Glossary\\_E\\_2013.pdf](http://ehedg.org/uploads/EHEDG_Glossary_E_2013.pdf)

### 3.1 - Basic Hygiene Classification for equipment

This applies to an area where a basic level of hygienic design can adequately minimize contamination risk to the product. The objective for a Basic Zone classification is to prevent product contamination by adopting good manufacturing procedures (cGMP), and to control or reduce the creation of hazardous sources that can affect zones of higher hygienic classification.

This zone relates to areas of the facility layout typically where a basic hygienic design criterion is required to minimize contamination risk where any of the following may be true:

- there is no open product handling. Products are generally covered, sealed, or in packed form.
- products of low or medium sensitivity to possible atmospheric contamination may be exposed to the environment for only short periods of time where equipment is likely temporarily opened e.g. sampling and inspection.
- products within this zone will undergo a further validated kill step to minimize contamination risks.
- the equipment requires a low degree of cleaning, inspection, and controls to minimize contamination risks.
- products are adequately protected from contamination by its packaging.

### 3.2 - High Hygiene classification for equipment

This applies to an area where the highest level of hygienic design criteria is essential. The objective for the zone classification is to prevent the creation of hazardous sources that can cause a contamination risk to the product prior to primary packaging. The objective for this zone classification is to control all product contamination hazards and to protect the product.

This zone relates to areas of the facility layout typically where the highest hygienic design criterion applies to the equipment involved to prevent contamination to the product where:

- there is continuous exposure to atmosphere of products sensitive to contamination or exposure of food contact surfaces to atmosphere.
- the equipment requires a high degree of cleaning, inspection, and controls to prevent contamination risks.
- there is processing of open, exposed, ready-to-eat products (RTE) prior to its primary packaging.
- products are not adequately protected by packaging from contamination.
- the products enter this zone from of a validated kill step to prevent contamination risk.
- there is a high risk to primary or secondary packaging.

## 4 CLEANING METHODS

An important aspect of hygienic design is the anticipated mode of cleaning as many aspects of the equipment construction and design will be directed by the cleaning and sanitizing requirements. The terms of wet clean and dry clean are often used to describe the removal of product and sanitizing efforts applied.

### 4.1 - Dry cleaning

This applies to areas where no aqueous cleaning liquids are used, and cleaning is by but not limited to vacuum cleaners, dusting cloths, brooms, and brushes. Dry cleaning is applicable for dry food material contact surfaces where:

- dry material remaining in the equipment as loose layers or dust covering does not present any risk of degrading the quality of the dry material subsequently produced;
- possible cross-contamination of dry material during a production change to another material presents no problem to the quality or safety of the dry material subsequently produced or the carryover of potential allergens into subsequent production;
- dry material remaining in the equipment does not present any risk of microbial growth occurring due to the prevailing moisture content, temperature and humidity conditions;
- dry material is non-hygroscopic and non-sticky.

### 4.2 - Wet cleaning

This applies to areas where the entire room or zone is always cleaned wet. The contents (equipment, cable trays, ceilings, walls etc.) are wet washed without restrictions on the amount of cleaning and rinsing liquid used. Some applications may be “controlled wet cleaned” based on the risk assessment and CPG’s equipment specifications.

## 5 DETERMINE THE HYGIENIC ZONES AND CLEANING METHODS - STEP 2

The JCP approach provides guidance for machinery manufacturers for the design and construction of machinery used in the production and packaging of Low-moisture foods. The design parameters for machinery in a facility manufacturing low moisture foods is driven by two major factors:

- In what hygienic zone is the machinery going to be located?
- How will the machinery be cleaned – wet clean or dry clean?

The resulting identification of the food type (low-moisture in this case), the zone of operation and the cleaning procedures required will inform CPG companies and OEM equipment manufacturers about many attributes and specifications that are critical for sanitary operation of the processing or packaging equipment functioning in that facility.

**FIGURE 5 – EQUIPMENT HYGIENE LEVEL DECISION TREE FOR LOW-MOISTURE FOODS**

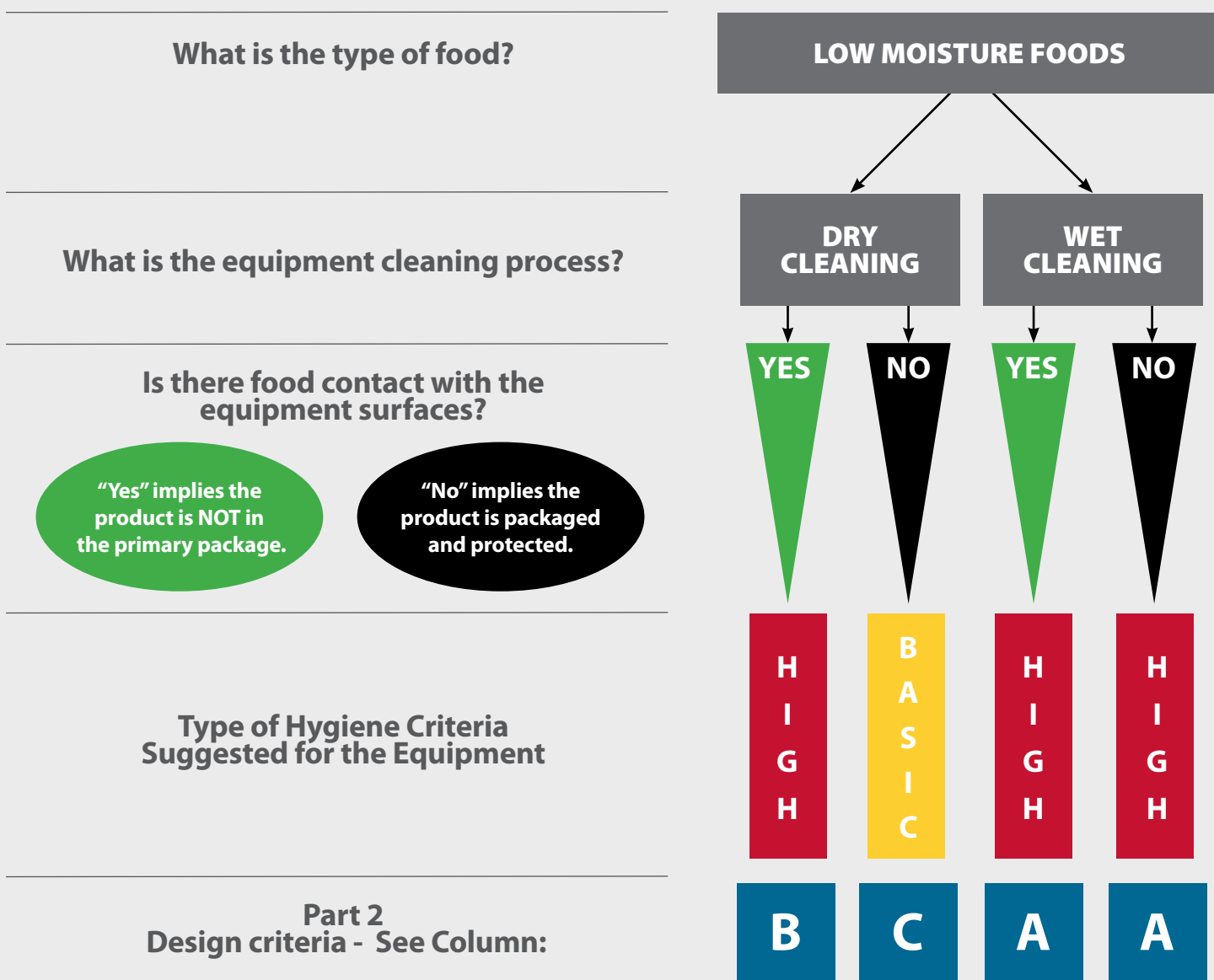

## 6 UTILIZE THE TOOLS - STEP 3

Using the JCP approach to identify common hygienic design criteria is facilitated with B155 TR3 Part 2 in this publication. Other tools list are referenced in the annex and are available through the web links provided.

Risk assessment will help categorize the food and the potential hazards associated with the food and the equipment it comes in contact within various zones. The output from the Hygiene Level Decision Tree (Figure 3) should be used to identify the most relevant column from B155 TR3 Part 2. Choosing column A, B or C will inform the user what hygienic design criteria identified by the ENGSG as “must have” criteria for that level of hygiene. B155 TR3 Part 2 is a very granular document that lists the criteria required to achieve the hygiene goal for each of the hygienic design categories.

With the hygiene zone information in hand and the appropriate column in B155 TR3 Part 2 identified (A, B or C), the next step is to review the design criteria in the column of B155 TR3 Part 2 with the OEM to determine the design specifications needed to meet that level of hygienic design for the specific equipment under consideration for the project. The CPG and OEM now have the design criteria required to review the individual specifications listed in B155 TR3 Part 2. Discussion can proceed to identify any areas that need further refinement or discussion.

## 7 HAVE DISCUSSIONS BETWEEN CPG & OEM - STEP 4

Successful operations depend on the right choice of equipment for the job at hand. A well-drafted specification of criteria not only sets the quality and performance standards for the equipment, but also provides the greatest possibility for maximising value. A good specification should be functional e.g. describing the equipment in terms of its intended function and the required level of performance, rather than by a generic description or brand name. It should be concise, but sufficiently detailed to enable manufacturers to take all costs into account, and also to offer alternative solutions. In particular, a good specification should:

- state the criteria for acceptance of the equipment
- abide by international and national quality and legal requirements
- include health and safety requirements

A CPG may find it desirable to conduct a risk assessment analysis using a team consisting of key stakeholders (internal and external). The team may conduct a brainstorming session identifying major cost elements and components parts of the equipment to assess whether or not such component parts may be modified or omitted, especially in light of hygienic design needs:

- What are its basic functions?
- Are they all necessary?
- Can they be simplified?
- Can they be performed in some other way?
- Are performance criteria and tolerances too stringent?
- Can standard methods and off-the-shelf equipment be used?
- Can operations be combined?
- Where can waste be reduced?
- What is the environmental impact, including costs of waste disposal?
- What are the staff cost implications in terms of numbers, expertise, etc?

### REVISIT RISK ASSESSMENT

Add to the Request for Proposal  
Use at Factory Acceptance Test

Potential Hazards	Corrective Actions
Short screen positioning studs (4 pieces) create lap joint against wall of housing	Weld studs in place, eliminate lap joint, remove bolts, puddle weld, polish
Gasket between sifter and frame. Create a lap joint to collect very small amounts of water.	Swab to validate. If not, seam weld sifter to frame
Wall to create barrier from main spray ball	Add spray ball on discharge side of wall; center existing sprayball over chamber
Material may build up going into chamber	Add one sprayball in chute
Bottom edge of supports cannot be reached by spray ball	Add two sprayballs for support braces
Four spray balls added	Upsize pump and feedline

The involvement of suppliers at this stage will help formulate the results of the investigation through discussions and perhaps offering to modify their equipment so as to reduce cost or improve performance.

What this JCP offers is the opportunity for buyers and sellers to have a basis for discussion about the intended hygienic design of the equipment and work toward agreement on specifications. By addressing a simple four step JCP approach, discussions can proceed more quickly to reach agreement on the basic hygienic design criteria.

Part 2 Criteria for the Design and Construction of Equipment Used to Manufacture Low-moisture Foods are part of this document. Part 2 represents the design criteria and information from several industry resources that was coalesced into a “what is important and how to achieve the basic hygienic design needs” tool. Part 2 is divided into five major sections: General, Informative References, Definitions, Materials of Construction, Design and Construction. Along with the text, it has many graphic examples of hygienic designs to assist in the construction and fabrication of equipment.

## CPG AND OEM COLLABORATE

The Criteria for the Design and Construction of Equipment Used to Manufacture Low-Moisture Foods

B155 TR3

One Voice for Hygienic Equipment Design for Low-Moisture Foods

A	B	C
<b>High Hygiene - Wet clean</b> NSF/ANSI-2-A 14159-1 - 2010	<b>High Hygiene - Dry clean</b>	<b>Basic Hygiene - Dry clean</b>
<p>3.30 smooth: The condition of a surface that satisfies hygienic requirements and is free of pits, pinholes, cracks, crevices, inclusions, rough edges, and other surface imperfections detectable by visual and tactile inspection.</p> <p>3.31 safe: Any unwanted matter (biological, chemical or physical)</p> <p>3.32 sterilizable (equipment): Designed to be capable of being sterilized.</p> <p>3.33 sterilization: A process that inactivates all microorganisms.</p> <p>3.34 surface treatment: The results of a process whereby chemical compositions or mechanical properties of the existing surface are altered. There is no appreciable, typically less than 40 µm (1 µm), build-up of new material or removal of existing material. Surface treatments include but are not limited to: mechanical (shot peening, glass beading, polishing), thermal (surface annealing, tempering, nitriding), diffusion (carburizing, nitriding), chemical (etching, oxidation), ion implantation, or electroplating.</p>		
<b>4 MATERIALS OF CONSTRUCTION</b>		
<b>High Hygiene - Wet clean</b>	<b>High Hygiene - Dry clean</b>	<b>Basic Hygiene - Dry clean</b>
<p>4.1 General</p> <p>Materials shall be suitable for their intended use.</p> <p>Surfaces of materials, coatings, and surface treatments shall be durable, cleanable, and if necessary, capable of being sanitized without breaking, cracking, chipping, flaking, delamination, erosion, corrosion, abrasion, and shall be resistant to the penetration of unwanted matter under intended use (non-absorbent).</p> <p>Equipment used in the manufacture of low moisture products shall be constructed of materials that will withstand the generally humid operating environment and high pressure, hot water cleaning with chemical cleaning agents.</p>	<p>4.1 General</p> <p>Materials shall be suitable for their intended use.</p> <p>Surfaces of materials, coatings, and surface treatments shall be durable, cleanable, and if necessary, capable of being sanitized without breaking, cracking, chipping, flaking, delamination, erosion, corrosion, abrasion, and shall be resistant to the penetration of unwanted matter under intended use (non-absorbent).</p>	<p>4.1 General</p> <p>Materials shall be suitable for their intended use.</p> <p>Surface of materials, coatings, and surface treatments shall be durable, cleanable, and if necessary, capable of being sanitized without breaking, cracking, chipping, flaking, delamination, erosion, corrosion, abrasion, and shall be resistant to the penetration of unwanted matter under intended use (non-absorbent).</p>

©2014 PMMI and NSF International 19

Same Criteria Across Equipment Classifications

Unique Criteria for each Equipment classification

Graphic Examples of Hygienic Equipment

B155 TR3

One Voice for Hygienic Equipment Design for Low-Moisture Foods

FIGURES B13 AND B14 - ACCESSIBILITY OF EQUIPMENT

Figure B13 - Accessible and High Hygiene

Figure B14 - Accessible and High Hygiene

©2014 PMMI and NSF International 42

## ANNEX A – TOOLS AND REFERENCES

### TOOLS

PackSafe/designsafe®, 2014. Software program designed to facilitate, speed up and standardize the risks assessment process. <http://www.pmmi.org/Resources/content.cfm?ItemNumber=979&navItemNumber=1092>

### REFERENCES

1. EN ISO 14159-1:2008 Safety of Machinery – Hygienic requirement for the design of machinery
2. AMI, January 2004. Sanitary Equipment Design Principles: Checklist & Glossary, AMI Foundation. <http://www.meatami.org/>
3. ANSI/PMMI, 2011. B155.1-2011 Safety Requirements for Packaging Machinery and Packaging-Related Converting Machinery. <http://webstore.ansi.org/RecordDetail.aspx?sku=ANSI%20FPMMI+B155.1-2011>
4. Food safety through HACCP - The FAO approach - Food and Agriculture Organization of the United Nations — <http://www.fao.org/docrep/v9723t/v9723t0e.htm>
5. GMA, 2010. The GMA Equipment Design Checklist for Low Moisture Foods. Version 2.0 May, 2010. <http://www.gmaonline.org/resources/research-tools/technical-guidance-and-tools/>
6. Schmidt, R. H. and D. J. Erickson, 2011. Hygienic design and Construction of Food Equipment. U. of Florida Extension. FSHN04-09. <http://edis.i.fas.ufl.edu/fs119>

# PART

# 2

Criteria for the design  
and construction of  
equipment used to  
manufacture  
low-moisture foods

## HARMONIZATION

High Hygiene wet cleaning design criteria have been used in the meat, poultry and dairy industry for many years. Therefore this document is based on NSF/ANSI/3-A 14159-1 – 2010 Hygiene requirements for the design of meat and poultry processing equipment. The basic requirements of NSF/ANSI/3-A 14159-1 – 2010 are harmonized with ISO 14159 which is the primary hygienic design standard listed in the Official Journal of the European Union for the EU machinery directive 2006/42/EC.

### Format of Part 2

The format of Part 2 is a table with columns header of A, B and C. These correspond to the output of Part 1 figure 5 which establishes the hygienic equipment criteria and method of cleaning indicated for a low-moisture food product. Column “A” was taken from NSF/ANSI/3-A 14159-1 – 2010 Hygiene Requirements for the Design of Meat and Poultry Processing Equipment.

The criteria contained in the row of column A, B or C represent the type of hygiene criteria suggested for the equipment and cleaning method. Rows that do not contain columns are requirement that apply to all 3 of the zones and cleaning methods.

<b>A</b>	<b>B</b>	<b>C</b>
<b>High Hygiene - Wet clean</b>	<b>High Hygiene - Dry clean</b>	<b>Basic Hygiene - Dry clean</b>
<b>Criteria for High Hygiene Wet clean</b>	<b>Criteria for High Hygiene Dry clean</b>	<b>Criteria for Basic Hygiene Dry clean</b>
<b>Hygienic equipment criteria that apply to all 3 cleaning methods</b>		
<b>High Hygiene - Wet clean</b> NSF/ANSI/3-A 14159-1 – 2010	<b>High Hygiene - Dry clean</b>	<b>Basic Hygiene - Dry clean</b>
<b>1 GENERAL</b>		
<p><b>1.1 Purpose</b></p> <p>This technical report identifies minimum food protection and sanitation criteria for the materials, design, fabrication, and construction of machinery used in the manufacture of low-moisture foods. The criteria are to be used by the CPG and OEM through the Joint Collaboration Process (JCP) and applied by OEMs to design and fabricate equipment used to manufacture low-moisture foods.</p> <p>This technical report does not contain operator safety requirements.</p>		
<p><b>1.2 Scope</b></p> <p>This technical report applies to equipment intended for use in the manufacture of low-moisture foods such as cereal, bakery products, pasta, pet foods, snack foods, confections, and similar foods.</p>		
<p><b>1.3 Measurement</b></p> <p>Decimal and metric (SI) conversions provided parenthetically shall be considered equivalent. Metric conversions have been made according to IEEE/ASTM SI 10.</p>		

<b>A</b>	<b>B</b>	<b>C</b>
<b>High Hygiene - Wet clean</b> NSF/ANSI/3-A 14159-1 – 2010	<b>High Hygiene - Dry clean</b>	<b>Basic Hygiene - Dry clean</b>

**1.4 Risk Assessment**

The risks assessment process should be used to assess the risk of product contamination by biological, chemical or physical sources. The equipment supplier and user should apply the risk reduction measures contained in the technical report to reduce the risk of product contamination to an acceptable level.

Deviation to the criteria contained in this technical report should be based on documented risk assessment.

**2 INFORMATIVE REFERENCES**

The following documents contain provisions that, through reference, constitute provisions of this technical report. At the time of publication, the editions indicated were valid. All referenced documents are subject to revision, and parties are encouraged to investigate the possibility of applying the most recent editions of the documents listed below.

**Risk assessment guidance documents:**

- ANSI/PMMI B155.1-2011 Safety Requirements for Packaging Machinery and Packaging-Related Converting Machinery
- ISO 12100 – 2010 Safety of Machinery – General Principles for Design – Risk Assessment and Risk Reduction

**3 DEFINITIONS**

**For the purposes of this Guideline, the following definitions apply.**

**3.1 associated equipment:** All appurtenances associated with a piece of equipment, not defined as equipment, that are essential to the functioning of the equipment for it to hygienically process a product (e.g., fittings, piping, tubing).

**3.2 bond:** The adhesive or cohesive forces holding materials together. This definition excludes press fits and shrink fits.

**3.3 cleanable:** Designed to be readily freed from soil.

**3.4 cleaned in place (CIP):** Cleaning of equipment by impingement or circulation of flowing chemical solutions, cleaning liquids, and water rinses, without dismantling, into, onto, and over surfaces in equipment or systems designed for this specific purpose.

**3.5 cleaning:** Removal of soil.

**3.6 coating:** The results of a process where a different material is deposited to create a new surface. There is appreciable, typically more than 40 μ in (1 μ m), build-up of new material. The coating material does not alter the physical properties of the substrate. Coating processes include but are not limited to: chemical (conversion coatings), engineering plating (e.g., electrodeposition gold), thermal spraying (e.g., flame, plasma, arc spray), physical vapor deposition, chemical vapor deposition, and overlays and encapsulation.

**3.7 consumer:** The end user of the product (including domestic animals).

**3.8 corrosion resistant material:** Capable of maintaining original surface characteristics under prolonged contact with the intended end use environment and the normal use of cleaning compounds and sanitizing solutions.

**3.9 crevice:** A sharp, cleft-like, irregular opening of small depth that adversely affects cleanability.

<b>A</b>	<b>B</b>	<b>C</b>
<b>High Hygiene - Wet clean</b> NSF/ANSI/3-A 14159-1 – 2010	<b>High Hygiene - Dry clean</b>	<b>Basic Hygiene - Dry clean</b>

- 3.10 dead space:** Space wherein product, cleaning or sanitizing agents, or soils can be trapped, retained, or not completely removed during the operation of cleaning.
- 3.11 easily accessible:** A location that can be reached by an employee from the floor, a platform, or other permanent work area.
- 3.12 easily removable:** Capable of being detached and taken away from the parent unit without or with the use of simple hand tools.
- 3.13 hygiene:** The taking of all measures during product handling, preparation, and processing to ensure its suitability for use by humans or domestic animals.
- 3.14 inspectable:** Designed such that all product contact surfaces can be made available for close visual observation
- 3.15 joint:** Junction of two or more pieces of material.
- 3.16 equipment:** An assembly of parts or components, with the appropriate actuators, controls, and power circuits, joined together for a specific application, in particular for the processing, treatment, moving, or packaging of product.
- 3.17 manual cleaning:** Cleaning by various methods that are manipulated by hand when the equipment is open or when partially or totally disassembled
- 3.18 microorganism (relevant):** Bacteria, fungi, yeasts, molds, spores, and viruses that are able to contaminate, multiply, or survive in a product and are able to be harmful.
- 3.19 non-absorbent materials:** Those materials that under the intended conditions of their use do not retain substances with which they come in contact.
- 3.20 non-product contact surface:** The exposed equipment surfaces that are not in contact with the product and from which product or other materials cannot drain, drip, diffuse, or be drawn (self-returned) into the product or product container.
- 3.21 non-toxic materials:** Substances that, under the conditions of their use, are in compliance with applicable requirements of the Food, Drug, and Cosmetic Act of 1938, as amended
- 3.22 pest:** Mammals, birds, reptiles, vermin, and insects that can adversely influence the product.
- 3.23 practical test:** Activities performed following a documented set of procedures and parameters used to determine an evaluation.
- 3.24 product:** Any substance intended to be applied or taken into humans or domestic animals (e.g., by ingestion, injection, topical application, insertion).
- 3.25 product contact surface:** Equipment surfaces that are exposed to the product and from which the product or other materials can drain, drip, diffuse, or be drawn (self-returned) into the product or product container
- 3.26 sanitization:** The application of cumulative heat, chemicals, or other approved agents on clean surfaces that is sufficient to reduce the population of disease organisms by at least 99.999% (5 log reduction).
- 3.27 seal:** To close an aperture so as to effectively prevent the entry or passage of unwanted matter.
- 3.28 self-draining:** The combination of design, construction, installation, and surface finish so as to prevent the retention of liquid except for normal surface wetting.
- 3.29 sensors:** Devices or instrumentation attached to equipment for process monitoring/control.

<b>A</b>	<b>B</b>	<b>C</b>
<b>High Hygiene - Wet clean</b> NSF/ANSI/3-A 14159-1 – 2010	<b>High Hygiene - Dry clean</b>	<b>Basic Hygiene - Dry clean</b>

**3.30 smooth:** The condition of a surface that satisfies hygienic requirements and is free of pits, pinholes, cracks, crevices, inclusions, rough edges, and other surface imperfections detectable by visual and tactile inspection.

**3.31 soil:** Any unwanted matter. (biological, chemical or physical)

**3.32 sterilizable (equipment):** Designed to be capable of being sterilized.

**3.33 sterilization:** A process that inactivates all microorganisms.

**3.34 surface treatment:** The results of a process whereby chemical compositions or mechanical properties of the existing surface are altered. There is no appreciable, typically less than 40 μ in (1 μ m), build-up of new material or removal of existing material. Surface treatments include but are not limited to: mechanical (shot peening, glass beading, polishing), thermal (surface hardening laser, electron), diffusion (carburizing, nitriding), chemical (etching, oxidation), ion implantation, or electropolishing.

## 4 MATERIALS OF CONSTRUCTION

<b>High Hygiene - Wet clean</b>	<b>High Hygiene - Dry clean</b>	<b>Basic Hygiene - Dry clean</b>
<p><b>4.1 General</b></p> <p>Materials shall be suitable for their intended use.</p> <p>Surfaces of materials, coatings, and surface treatments shall be durable, cleanable, and if necessary, capable of being sanitized without breaking, cracking, chipping, flaking, delamination, erosion, corrosion, abrasion, and shall be resistant to the penetration of unwanted matter under intended use (non-absorbent).</p> <p>Equipment used in the manufacture of low moisture products shall be constructed of materials that will withstand the generally humid operating environment and high pressure, hot water cleaning with chemical cleaning agents.</p>	<p><b>4.1 General</b></p> <p>Materials shall be suitable for their intended use.</p> <p>Surfaces of materials, coatings, and surface treatments shall be durable, cleanable, and if necessary, capable of being properly dry cleaned and sanitized without breaking, cracking, chipping, flaking, delamination, erosion, corrosion, abrasion, and shall be resistant to the penetration of unwanted matter under intended use (non-absorbent).</p>	<p><b>4.1 General</b></p> <p>Materials shall be suitable for their intended use.</p> <p>Surfaces of materials, coatings, and surface treatments shall be durable, cleanable, and if necessary, capable of being properly dry cleaned and non-aqueous sanitized without breaking, cracking, chipping, flaking, delamination, erosion, corrosion, abrasion, and shall be resistant to the penetration of unwanted matter under intended use (non-absorbent).</p>

<b>A</b>	<b>B</b>	<b>C</b>
<b>High Hygiene - Wet clean</b>	<b>High Hygiene - Dry clean</b>	<b>Basic Hygiene - Dry clean</b>
<p><b>4.1.1 Unacceptable materials</b></p> <p>The following materials shall not be used in product contact surface areas or non-product contact surface areas:</p> <ul style="list-style-type: none"> <li>■ materials containing antimony, arsenic, cadmium, lead, or mercury;</li> <li>■ materials classified as hazardous substances (such as carcinogens, mutagens and teratogens);</li> <li>■ asbestos and asbestos containing materials;</li> <li>■ wood;</li> <li>■ enamelware;</li> <li>■ porcelain</li> <li>■ leather;</li> <li>■ uncoated aluminum and aluminum alloys; and</li> <li>■ uncoated anodized aluminum and aluminum alloys.</li> </ul>	<p><b>4.1.1 Unacceptable materials</b></p> <p>The following materials shall not be used in product contact surface areas or non-product contact surface areas:</p> <ul style="list-style-type: none"> <li>■ materials containing antimony, arsenic, cadmium, lead, or mercury;</li> <li>■ materials classified as hazardous substances (such as carcinogens, mutagens and teratogens);</li> <li>■ asbestos and asbestos containing materials;</li> <li>■ wood;</li> <li>■ enamelware;</li> <li>■ porcelain;</li> <li>■ leather;</li> <li>■ uncoated aluminum and aluminum alloys</li> </ul>	<p><b>4.1.1 Unacceptable materials</b></p> <p>The following materials shall not be used in product contact surface areas or non-product contact surface areas:</p> <ul style="list-style-type: none"> <li>■ materials containing antimony, arsenic, cadmium, lead, or mercury;</li> <li>■ materials classified as hazardous substances (such as carcinogens, mutagens and teratogens);</li> <li>■ asbestos and asbestos containing materials;</li> <li>■ wood;</li> <li>■ enamelware;</li> <li>■ porcelain;</li> <li>■ leather</li> </ul>
<p><b>4.2 Product contact surfaces</b></p> <p>In addition to the general criteria (see 4.1), materials used for product contact surfaces shall:</p> <ul style="list-style-type: none"> <li>■ be corrosion resistant to both product and cleaning/sanitization materials;</li> <li>■ be non-toxic;</li> <li>■ not contaminate or otherwise have any adverse effect on the product;</li> <li>■ be non-absorbent (except where technically or functionally unavoidable); and</li> <li>■ be temperature resistant to processing and heat treatments where necessary (e.g., freezing, heat-sterilization).</li> </ul>		

<b>A</b>	<b>B</b>	<b>C</b>
<b>High Hygiene - Wet clean</b>	<b>High Hygiene - Dry clean</b>	<b>Basic Hygiene - Dry clean</b>
<b>4.2.1 Metals</b>		
<p><b>4.2.1.1 Product contact surfaces shall be:</b></p> <ul style="list-style-type: none"> <li>■ AISI 300 series stainless steel; or</li> <li>■ of stainless steel of a type appropriate for the application; or</li> <li>■ when necessary, stainless steel that has been hardened by heat treatment or precipitation hardening, including martensitic stainless steel; or</li> <li>■ other alloys that can be shown to be as corrosion resistant as austenitic stainless steel and are non-absorbent and non-toxic; or</li> <li>■ other metals and metal alloys (including solder) suitable for the conditions of intended use.</li> </ul>	<p><b>4.2.1.1 Product contact surfaces shall be:</b></p> <ul style="list-style-type: none"> <li>■ AISI 300 series stainless steel; or</li> <li>■ of stainless steel of a type appropriate for the application; or</li> <li>■ when necessary, stainless steel that has been hardened by heat treatment or precipitation hardening, including martensitic stainless steel; or</li> <li>■ other alloys that can be shown to be as corrosion resistant as austenitic stainless steel and are non-absorbent and non-toxic; or</li> <li>■ other metals and metal alloys (including solder) suitable for the conditions of intended use.</li> </ul>	<p><b>4.2.1.1 Product contact surfaces shall conform to the general criteria in 4.2.</b></p>
<p><b>4.2.1.2</b> Copper and copper alloys, bronze, brass, other soft metals, and zinc galvanizing shall not be used for product contact surfaces. These materials may be used in supply air and supply water lines or for gears and bushings used in non-product contact surfaces.</p>		
<p><b>4.2.1.3</b> Surface coatings and platings may be used if the base material is non-toxic and non-absorbent. Coatings shall meet the criteria of 4.2.2.</p>		
<p><b>4.2.2 Non-metals</b></p> <p>Product contact surfaces shall be manufactured from or composed of substances that:</p> <ul style="list-style-type: none"> <li>■ may not reasonably be expected to result, directly or indirectly, in their becoming a component of food or otherwise affecting the characteristics of food, including the imparting of a color, taste, or odor to food; or</li> <li>■ are generally recognized as safe or have received prior sanction for their intended use; or</li> <li>■ are regulated as indirect food additives under the provisions of 21 CFR, parts 174-189; or</li> <li>■ are exempt from regulation as food additives under the provisions of the 21 CFR, part 170.39; or</li> <li>■ can be demonstrated to be safe for the intended use, subject to the Food, Drug, and Cosmetic Act, Section 409(h)(1) [21 U.S.C. 348(h)(1)], Premarket Notification.</li> </ul>		

<b>A</b>	<b>B</b>	<b>C</b>
<b>High Hygiene - Wet clean</b>	<b>High Hygiene - Dry clean</b>	<b>Basic Hygiene - Dry clean</b>
<p><b>4.2.2.1</b> Elastomers and polymers having product contact surfaces shall be of such composition as to retain their surface and conformational characteristics when exposed to the conditions encountered in the environment of intended use and in cleaning and sanitization or sterilization.</p>		
<p><b>4.2.2.2</b> Adhesives and the bonds created by their use shall be compatible with the surfaces, products, and cleaning/sanitizing materials in which they are in contact. All bonds materials shall be continuous and mechanically sound so that the adhesives do not separate from the base materials to which they are bonded.</p>		
<p><b>4.2.2.3</b> Where materials having certain inherent functional purposes are required for specific application, product contact surfaces may be made of these materials (e.g., carbon, sapphire, quartz, fluorspar, spinel, ceramic materials).</p>		
<p><b>4.2.2.4</b> Surface coatings and platings may be used if the base material is non-toxic. Coatings shall meet the criteria of 4.2.2.</p>		
<p><b>4.2.2.5</b> Gaskets, O-rings, etc., shall be non-toxic, non-porous, non-absorbent, and unaffected by food products.</p>		
<p><b>4.2.2.6</b> Absorbent fabric may only be used for single use applications, e.g., single service filters</p>		
<p><b>4.3 Non-product contact surfaces</b></p> <p>In addition to the general criteria (see 4.1), materials used for non-product contact surfaces under the conditions of intended use, shall:</p> <ul style="list-style-type: none"> <li>■ be of corrosion resistant material or material that is treated (e.g., coating, painting) so as to be corrosion resistant to both product and cleaning/sanitizing materials. When coated, the coating shall adhere;</li> <li>■ be non-absorbent (except where allowed under 4.2.2.6); and</li> <li>■ not contaminate or otherwise have any adverse effect on the product.</li> </ul> <p>Parts removable for cleaning having both product contact and non-product contact surfaces shall be designed to ensure that hygiene risks are eliminated in accordance with the criteria for product contact surfaces.</p>		

<b>A</b>	<b>B</b>	<b>C</b>
<b>High Hygiene - Wet clean</b>	<b>High Hygiene - Dry clean</b>	<b>Basic Hygiene - Dry clean</b>
<b>5 DESIGN AND CONSTRUCTION</b>		
<b>5.1 Product contact surfaces</b>		
<p><b>5.1.1 Surface texture</b></p> <p>Surfaces shall be free of imperfections such as pits, folds, cracks, and crevices.</p> <p>Surface textures shall have a maximum profile roughness parameter (Ra) of 32 <math>\mu</math> in (0.81 <math>\mu</math> m). When necessary, due to functionality needs, the following may be used:</p> <ul style="list-style-type: none"> <li>■ Glass-beaded or shot-peened surfaces shall have a maximum Ra of 125 <math>\mu</math> in (3.2 <math>\mu</math> m).</li> <li>■ Coatings shall have a maximum Ra of 125 <math>\mu</math> in (3.2 <math>\mu</math> m).</li> <li>■ Machined plastics shall have a maximum Ra of 125 <math>\mu</math> in (3.2 <math>\mu</math> m).</li> </ul> <p><b>NOTE</b> – The 2B mill finish on stainless steel sheet is also considered as smooth or smoother than a No. 4 finish. No further finishing is required if the finish is free of defects, such as pits, scratches, chips, or flakes in the final fabricated form.</p>	<p><b>5.1.1 Surface texture</b></p> <p>Surfaces shall be free of imperfections such as pits, folds, cracks, and crevices.</p> <p>Surface textures shall have a maximum profile roughness parameter (Ra) of 32 <math>\mu</math> in (0.81 <math>\mu</math> m). When necessary, due to functionality needs, the following may be used:</p> <ul style="list-style-type: none"> <li>■ Glass-beaded or shot-peened surfaces shall have a maximum Ra of 125 <math>\mu</math> in (3.2 <math>\mu</math> m).</li> <li>■ Coatings shall have a maximum Ra of 125 <math>\mu</math> in (3.2 <math>\mu</math> m).</li> <li>■ Machined plastics shall have a maximum Ra of 125 <math>\mu</math> in (3.2 <math>\mu</math> m).</li> </ul> <p><b>NOTE</b> – The 2B mill finish on stainless steel sheet is also considered as smooth or smoother than a No. 4 finish. No further finishing is required if the finish is free of defects, such as pits, scratches, chips, or flakes in the final fabricated form.</p>	<p><b>5.1.1 Surface texture</b></p> <p>Surfaces shall be free of imperfections such as pits, folds, cracks, and crevices.</p> <p>Surface textures shall have a maximum profile roughness parameter (Ra) of 125 <math>\mu</math> in (3.2 <math>\mu</math> m). When necessary, due to functionality needs, the following may be used:</p> <ul style="list-style-type: none"> <li>■ Glass-beaded or shot-peened surfaces shall have a maximum Ra of 125 <math>\mu</math> in (3.2 <math>\mu</math> m).</li> <li>■ Coatings shall have a maximum Ra of 200 <math>\mu</math> in (5.0 <math>\mu</math> m).</li> <li>■ Machined plastics shall have a maximum Ra of 125 <math>\mu</math> in (3.2 <math>\mu</math> m).</li> </ul>
<p><b>5.1.2 Cleaning and inspection</b></p> <p>Surfaces shall be cleanable. For equipment intended to be disassembled, the design shall ensure that product contact surfaces be easily accessible for cleaning and inspection, and the demountable parts shall be easily removable.</p> <p>Alternatively, equipment designed to be cleaned without disassembly shall be designed so that product contact surfaces and all non-removed appurtenances thereto can be manually cleaned and are easily accessible and easily removable for inspection.</p>	<p><b>5.1.2 Cleaning and inspection</b></p> <p>Surfaces shall be cleanable. For equipment intended to be disassembled, the design shall ensure that product contact surfaces be easily accessible for cleaning and inspection, and the demountable parts shall be easily removable.</p> <p>Alternatively, equipment designed to be cleaned without disassembly shall be designed so that product contact surfaces and all non-removed appurtenances thereto can be manually cleaned and are easily accessible and easily removable for inspection.</p>	<p><b>5.1.2 Cleaning and inspection</b></p> <p>Surfaces shall be cleanable. For equipment intended to be disassembled, the design shall ensure that product contact surfaces be easily accessible for cleaning and inspection, and the demountable parts shall be easily removable.</p> <p>Alternatively, equipment designed to be cleaned without disassembly shall be designed so that product contact surfaces and all non-removed appurtenances thereto can be manually cleaned and are easily accessible for inspection.</p>

<b>A</b>	<b>B</b>	<b>C</b>
<b>High Hygiene - Wet clean</b>	<b>High Hygiene - Dry clean</b>	<b>Basic Hygiene - Dry clean</b>
<p><b>5.1.3 Sanitation or Sterilization</b> Where appropriate, equipment shall be designed such that all product contact surfaces can attain the required sanitization or sterilization conditions.</p>	<p><b>5.1.3 Sanitation or Sterilization</b> Where appropriate, equipment shall be designed such that all product contact surfaces can attain the required non aqueous sanitization.</p>	<p><b>5.1.3 Sanitization - sterilization is not required</b> Where appropriate, equipment shall be designed such that all product contact surfaces can attain the required non aqueous sanitization.</p>
<p><b>5.1.4 Microbial ingress</b> Where appropriate equipment should be designed to avoid microorganisms being introduced from the external environment onto product contact surfaces, either directly or via soils.</p>		
<p><b>5.1.5 Draining</b> Surfaces of equipment intended to drain shall be self draining or be drainable (see figures B.1 and B.2).</p>	<p><b>5.1.5 Draining</b> Surfaces of equipment intended to drain shall be self draining or be drainable (see figures B.1 and B.2).</p>	<p><b>5.1.5 Accumulation</b> Surfaces should be so designed that they avoid accumulation of soil and be cleanable.</p>
<p><b>5.1.6 Dead spaces</b> There shall be no dead spaces (see figure B.3).</p>		
<p><b>5.1.7 Joints</b></p>		
<p><b>5.1.7.1</b> Permanent metal-to-metal joints shall be continuously welded. Jointed surfaces shall be flush (see figure B.4).</p>		
<p><b>5.1.7.2</b> Dismountable joints shall be flush and sealed at the product contact surface (see figure B.5).</p>		
<p><b>5.1.7.3</b> Only in cases where welding or bonding is impractical, silver soldering, press fitting or shrink fitting may be employed where necessary for essential functionality</p>		
<p><b>5.1.7.4</b> Silver-bearing solder may be used for flushing joints and producing fillets for minimum radii criteria. In cases where welding is impractical, silver-bearing solder may be used for essential functions, such as mounting of cutting blades and cutting blade mounting pins and bushings.</p>		
<p><b>5.1.7.5</b> Welding, press fitting, shrink fitting or soldering shall produce product contact surfaces with a smooth finish free of imperfections such as pits, folds, inclusions, cracks and crevices.</p>		

<b>A</b>	<b>B</b>	<b>C</b>
<b>High Hygiene - Wet clean</b>	<b>High Hygiene - Dry clean</b>	<b>Basic Hygiene - Dry clean</b>
<p><b>5.1.8 Coatings</b></p> <p>Coatings shall be free from surface delamination, pitting, flaking, spalling, blistering, and distortion. Surface coatings and platings must remain intact. Surface coatings shall not crack or peel. Coatings and platings shall not be used on product contact surfaces that are not inspectable. Paint shall not be used on product contact surfaces or on parts having both product contact and non-product contact surfaces.</p>		
<p><b>5.1.9 Internal angles, corners and grooves</b></p> <p>Internal corners and angles of less than 135° in product contact areas shall have smooth and continuous radius 1/8 in (0.13 in, 3.2 mm) or greater. Lesser radii may be used for necessary functional reasons or to facilitate drainage provided these areas can be readily cleaned. The radii shall not be less than 1/32 in (0.031 in, 0.79 mm) except that the radius intersection of press-fits, shrink-fits, and flat sealing surfaces may be zero.</p> <p>Internal three-plane intersections shall have a radius of 1/4 in (0.25 in, 6.4 mm) or greater. Where used, grooves shall be wider than their depth.</p>		
<p><b>5.1.10 Seals, gaskets, O-rings, joint rings</b></p>		
<p><b>5.1.10.1</b> Seals, gaskets, O-rings and joint rings shall be designed to minimize product contact and be cleanable</p>		
<p><b>5.1.10.2</b> Excessive compression can cause damage to rubber components and can cause the elastomer to extrude into the product zone adversely affecting cleanability. Where an elastomer is used as a seal between solid surfaces, the compression of the elastomer shall be controlled (see figure B.7).</p>		
<p><b>5.1.11 Fasteners</b></p> <p>Fasteners (e.g., screws, bolts, rivets) shall be avoided. Where technically unavoidable, fasteners shall be cleanable (see figure B.8). There shall be no exposed screw threads or recesses.</p> <p>Threads which may become product contact surfaces during dismantling operations should be designed to be cleanable, such as ACME 60° Stub, or equal, with not more than 14 threads per inch and a with a major diameter of not less than 5/16 in (0.31 in, 7.9 mm).</p>		
<p><b>5.1.12 Process flow disruption caused by intrusions</b></p> <p>Intrusions (e.g., springs, openings, perforations) shall be avoided except where functionally necessary.</p> <p>Where necessary, such process flow disruptions and intrusions shall be cleanable in place or easily accessible for cleaning, sanitizing, and inspection.</p>		
<p><b>5.1.13 Shafts and bearings</b></p>		

<b>A</b>	<b>B</b>	<b>C</b>
<b>High Hygiene - Wet clean</b>	<b>High Hygiene - Dry clean</b>	<b>Basic Hygiene - Dry clean</b>
<p><b>5.1.13.1</b> Where shaft seals are required, they shall be hygienic in design (i.e., packless) and shall be easily accessible for cleaning sanitizing, and inspection.</p>		
<p><b>5.1.13.2</b> Where a shaft passes through a product contact surface, the portion of the opening surrounding the shaft shall be protected to prevent the entrance of contaminants (see figure B.9).</p>		
<p><b>5.1.13.3</b> Lubricated bearings, including the permanent sealed type, shall be located outside the product contact surface with adequate clearance open for inspection between the bearing and any product contact surface (see figure B.9).</p>		
<p><b>5.1.13.4</b> Bearings or bushings having a product contact surface shall be avoided. When technically necessary, these bearings or bushings shall be of a non-lubricated or product-lubricated type (see figure B.10) and be cleanable. When a bottom support bearing or bushing is used, it shall not interfere with drainage of the equipment.</p>	<p><b>5.1.13.4</b> Bearings or bushings having a product contact surface shall be avoided. When technically necessary, these bearings or bushings shall be of a non-lubricated or product-lubricated type (see figure B.10) and be cleanable.</p>	<p><b>5.1.13.4</b> Bearings or bushings having a product contact surface shall be avoided. When technically necessary, these bearings or bushings shall be of a non-lubricated or product-lubricated type (see figure B.10) and be</p>
<p><b>5.1.13.5</b> When provided, a shaft driving mechanism shall be securely mounted in a position that ensures a physical separation from product contact surfaces for cleaning and inspection.</p>		
<p><b>5.1.14</b> <b>Sensor and sensor connections</b> All sensors and sensor connections having product contact surfaces shall be installed to avoid crevices and dead spaces and be drainable (see figure B.3).</p>	<p><b>5.1.14</b> <b>Sensor and sensor connections</b> All sensors and sensor connections having product contact surfaces shall be installed to avoid crevices and dead spaces (see figure B.3).</p>	<p><b>5.1.14</b> <b>Sensor and sensor connections</b> All sensors and sensor connections having product contact surfaces shall be installed to avoid crevices and dead spaces (see figure B.3).</p>
<p><b>5.1.15 Other connections</b> All pipelines and other appendages entering the equipment shall be hygienically sealed and designed to prevent the ingress of soil.</p>		
<p><b>5.1.16 Openings and covers</b></p>		
<p><b>5.1.16.1</b> Panels, covers, and doors shall be so designed that they avoid any adverse influence (e.g., entry and/or accumulation of soil) and shall be cleanable (see figure B.11).</p>		

<b>A</b>	<b>B</b>	<b>C</b>
<b>High Hygiene - Wet clean</b>	<b>High Hygiene - Dry clean</b>	<b>Basic Hygiene - Dry clean</b>
<p><b>5.1.16.2</b> If any exterior flange is incorporated in the opening, it shall slope and drain away from the opening.</p>	<p><b>5.1.16.2</b> If any exterior flange is incorporated in the opening, it shall slope and drain away from the opening.</p>	<p><b>5.1.16.2</b> If any exterior flange is incorporated in the opening, it shall slope away from the opening.</p>
<p><b>5.1.16.3</b> Covers shall be sloped to an outside edge(s).</p>		
<p><b>5.2 Non-product contact surfaces</b></p>		
<p><b>5.2.1 General</b></p> <p>All equipment, supports, and framework shall be designed in such a manner as to prevent the retention of moisture and the ingress and harborage of pests and soils. All equipment, supports, and framework shall be designed in such a manner as to facilitate cleaning, inspection, servicing and maintenance. Equipment shall be designed such that non-product surfaces can attain the required sanitization or sterilization conditions.</p> <p>Permanent metal-to-metal joints shall be continuously welded wherever possible; when not possible, permanent metal-to-metal joints shall be completely sealed. Permanent metal-to-non-metal or non-metal-to- non-metal joints shall be continuously bonded.</p> <p>Equipment to be mounted without supports shall be designed to allow the installer of the equipment to mount flush and seal the equipment to the supporting surface (see figure B.13).</p> <p>There shall be no dead spaces.</p>	<p><b>5.2.1 General</b></p> <p>All equipment, supports, and framework shall be designed in such a manner as to prevent the ingress and harborage of pests and soils. All equipment, supports, and framework shall be designed in such a manner as to facilitate cleaning, inspection, servicing and maintenance. Equipment shall be designed such that non-product surfaces can attain the required non aqueous sanitization.</p> <p>Permanent metal-to-metal, metal to non-metal or non-metal to non-metal joints should be continuously welded, bonded or sealed, and shall be based on the results of the application / product specific risk assessment.</p> <p>Equipment to be mounted without supports shall be designed to allow the installer of the equipment to mount flush and seal the equipment to the supporting surface (see figure B.13).</p> <p>There shall be no dead spaces.</p>	<p><b>5.2.1 General</b></p> <p>All equipment, supports, and framework shall be designed in such a manner as to prevent the ingress and harborage of pests and soils. All equipment, supports, and framework shall be designed in such a manner as to facilitate cleaning, inspection, servicing and maintenance. Equipment shall be designed such that non-product surfaces can attain the required non aqueous sanitization.</p> <p>Equipment to be mounted without supports shall be designed to allow the installer of the equipment to mount flush and seal the equipment to the supporting surface (see figure B.13).</p> <p>There shall be no dead spaces.</p>

<b>A</b>	<b>B</b>	<b>C</b>
<b>High Hygiene - Wet clean</b>	<b>High Hygiene - Dry clean</b>	<b>Basic Hygiene - Dry clean</b>
<p><b>5.2.2 Surface texture</b></p> <p>Surfaces shall be free of imperfections such as pits, folds, cracks, and crevices.</p> <p>Surface textures the following may be used:</p> <ul style="list-style-type: none"> <li>■ Exposed equipment surfaces including purchased components shall have a maximum Ra of 125 μ in (3.2 μ m).</li> <li>■ Glass-beaded or shot-peened surfaces shall have a maximum Ra of 125 μ in (3.2 μ m).</li> <li>■ Coatings shall have a maximum Ra of 125 μ in (3.2 μ m).</li> <li>■ Machined plastics shall have a maximum Ra of 125 μ in (3.2 μ m).</li> </ul>	<p><b>5.2.2 Surface texture</b></p> <p>Surfaces shall be free of imperfections such as pits, folds, cracks, and crevices.</p>	<p><b>5.2.2 Surface texture</b></p> <p>Surfaces shall be free of imperfections such as pits, folds, cracks, and crevices.</p>
<p><b>5.2.3 Cleaning and inspection</b></p> <p>Surfaces shall be cleanable and inspectable.</p>		
<p><b>5.2.4 Sanitization</b></p> <p>Where appropriate, equipment shall be designed such that all non-product contact surfaces can attain the required sanitization.</p>		
<p><b>5.2.5 Draining</b></p> <p>Surfaces of equipment intended to drain shall be self-draining or be drainable (see figures B.1 and B.2).</p>	<b>NOT APPLICABLE</b>	<b>NOT APPLICABLE</b>
<p><b>5.2.6 Dead spaces</b></p> <p>There shall be no dead spaces (see figure B.3).</p>		
<p><b>5.2.7 Joints</b></p>		
<p><b>5.2.7.1</b> Permanent metal-to-metal joints shall be continuously welded. Jointed surfaces shall be flush (see figure B.4).</p>		

<b>A</b>	<b>B</b>	<b>C</b>
<b>High Hygiene - Wet clean</b>	<b>High Hygiene - Dry clean</b>	<b>Basic Hygiene - Dry clean</b>
<p><b>5.2.7.2</b> Only in cases where welding or bonding is impractical, silver soldering, press fitting or shrink fitting may be employed where necessary for essential functionality reasons.</p>		
<p><b>5.2.7.3</b> Silver-bearing solder may be used for flushing joints and producing fillets for minimum radii criteria. In cases where welding is impractical, silver-bearing solder may be used for essential functions.</p>		
<p><b>5.2.7.4</b> Welding, press fitting, shrink fitting or soldering shall produce surfaces with a smooth finish free of imperfections such as pits, folds, inclusions, cracks and crevices.</p>		
<p><b>5.2.8 Coatings</b></p> <p>Coatings shall be free from surface delamination, pitting, flaking, spalling, blistering, and distortion. Surface coatings and platings must remain intact. Surface coatings shall not crack or peel. Coatings and platings shall not be used on non-product contact surfaces that are not inspectable.</p> <p>Paint shall not be used on product contact surfaces or on parts having both product contact and non-product contact surfaces.</p>	<p><b>5.2.8 Coatings and Paint</b></p> <p>Coatings and paint shall be free from surface delamination, pitting, flaking, spalling, blistering, and distortion.</p> <p>Coatings and paint must remain intact. Surface coatings shall not crack or peel. Coatings and paint shall not be used on non-product contact surfaces that are not inspectable.</p>	<p><b>5.2.8 Coatings and Paint</b></p> <p>Coatings and paint shall be free from surface delamination, pitting, flaking, spalling, blistering, and distortion.</p> <p>Coatings and paint must remain intact. Surface coatings shall not crack or peel. Coatings and paint shall not be used on non-product contact surfaces that are not inspectable.</p>
<p><b>5.2.9 Internal angles, corners and grooves</b></p> <p>Internal corners and angles of less than 135° in non-product contact areas shall have smooth and continuous radius 1/8 in (0.13 in, 3.2 mm) or greater. Lesser radii may be used for necessary functionality reasons or to facilitate drainage provided these areas can be readily cleaned. The radii shall not be less than 1/32 in (0.031 in, 0.79 mm) except that the radius intersection of press-fits, shrink-fits, and flat sealing surfaces may be zero.</p> <p>Internal three-plane intersections shall have a radius of 1/4 in (0.25 in, 6.4 mm) or greater. Where used, grooves shall be wider than their depth.</p>	<p><b>5.2.9 Internal angles, corners and grooves</b></p> <p>Internal corners and angles of less than 135° in non-product contact areas shall have smooth and continuous radius 1/8 in (0.13 in, 3.2 mm) or greater. Lesser radii may be used for necessary functionality reasons or to facilitate drainage provided these areas can be readily cleaned. The radii shall not be less than 1/32 in (0.031 in, 0.79 mm) except that the radius intersection of press-fits, shrink-fits, and flat sealing surfaces may be zero.</p> <p>Internal three-plane intersections shall have a radius of 1/4 in (0.25 in, 6.4 mm) or greater. Where used, grooves shall be wider than their depth.</p>	<p><b>5.2.9 Internal angles, corners and grooves</b></p> <p>Internal corners and angles of less than 135° non-in product contact areas shall have smooth and continuous radius 1/8 in (0.13 in, 3.2 mm) or greater. Lesser radii may be used for necessary functionality reasons or to facilitate drainage provided these areas can be readily cleaned. The radii shall not be less than 1/32 in (0.031 in, 0.79 mm) except that the radius intersection of press-fits, shrink-fits, and flat sealing surfaces may be zero.</p> <p>Internal three-plane intersections shall have a radius of 1/4 in (0.25 in, 6.4 mm) or greater. Where used, grooves shall be wider than their depth.</p>

<b>A</b>	<b>B</b>	<b>C</b>
<b>High Hygiene - Wet clean</b>	<b>High Hygiene - Dry clean</b>	<b>Basic Hygiene - Dry clean</b>
<b>5.2.10 Seals, gaskets, O-rings, joint rings</b>		
<b>5.2.10.1 Seals, gaskets, O-rings, joint rings</b> Seals, gaskets, O-rings and joint rings shall be designed to be cleanable.		
<b>5.2.10.2</b> Excessive compression can cause damage to rubber components and can cause the elastomer to extrude into the product zone adversely affecting cleanability. Where an elastomer is used as a seal between solid surfaces, the compression of the elastomer shall be controlled (see figure B.7).		
<b>5.2.11 Fasteners</b> Fasteners (e.g., screws, bolts, rivets) should be avoided. Where technically unavoidable, fasteners shall be cleanable (see figure B.8). If a fastener is necessary in a non-product contact area, a bolt of hex-head design with exposed threads less than ½ of the diameter of the fastener may be used Pop rivets, rivets, recessed socket-head and slot-head style bolts or screws are not acceptable.		
<b>5.2.12 Shafts and bearings</b>		
<b>5.2.12.1</b> Where bearing and shaft seals are required, they shall be hygienic in design (i.e., packless) and shall be easily accessible for cleaning sanitizing, and inspection.		
<b>5.2.12.2</b> When provided, a shaft driving mechanism shall be securely mounted in a position that ensures a physical separation from product contact surfaces for cleaning and inspection.		
<b>5.2.13 Control systems components and installation</b> Control systems components shall be selected and installed to be cleanable, avoid crevices and dead spaces and be drainable Continuous, piano type hinges may not be used.	<b>5.2.13 Control systems components and installation</b> Control systems components shall be selected and installed to be cleanable, avoid crevices and dead spaces and be drainable Continuous, piano type hinges may not be used.	<b>5.2.13 Control systems components and installation</b> Control systems components shall be selected and installed to be cleanable, avoid crevices and dead spaces Continuous, piano type hinges are not preferred but may be used on electrical boxes only when they are located well outside of the product zone

<b>A</b>	<b>B</b>	<b>C</b>
<b>High Hygiene - Wet clean</b>	<b>High Hygiene - Dry clean</b>	<b>Basic Hygiene - Dry clean</b>
<p><b>5.2.14 Other connections</b></p> <p>All pipelines and other appendages entering the equipment shall be hygienically sealed and designed to prevent the ingress of soil and shall not block access for cleaning or removal of parts for cleaning.</p>		
<p><b>5.2.16 Openings and covers</b></p>		
<p><b>5.2.16.1</b> Panels, covers, and doors shall be so designed that they avoid any adverse influence (e.g., entry and/or accumulation of soil) and shall be cleanable (see figure B.11).</p>		
<p><b>5.2.16.2</b> If any exterior flange is incorporated in the opening, it shall slope and drain away from the opening.</p>	<p><b>5.2.16.2</b> If any exterior flange is incorporated in the opening, it shall slope away from the opening.</p>	<p><b>5.2.16.2</b> If any exterior flange is incorporated in the opening, it shall slope away from the opening.</p>
<p><b>5.2.17 Cleaning and inspection</b></p> <p>Surfaces shall be cleanable. For equipment intended to be disassembled, the design shall ensure that relevant areas are easily accessible for cleaning, and inspection and the demountable parts shall be easily removable.</p> <p>Alternatively, equipment may be designed to be cleaned in place. Cleaned without disassembly equipment shall be designed to allow access for inspection after cleaning.</p>	<p><b>5.2.17 Cleaning and inspection</b></p> <p>Surfaces shall be cleanable. For equipment intended to be disassembled, the design shall ensure that relevant areas are easily accessible for cleaning, and inspection and the demountable parts shall be easily removable.</p> <p>Alternatively, equipment may be designed to be cleaned in place. Cleaned without disassembly equipment shall be designed to allow access for inspection after cleaning.</p>	<p><b>5.2.17 Cleaning and inspection</b></p> <p>Surfaces shall be cleanable. For equipment intended to be disassembled, the design shall ensure that non product contact surfaces be easily accessible for cleaning and inspection, and the demountable parts shall be easily removable.</p> <p>Alternatively, equipment designed to be cleaned without disassembly shall be designed so that non product contact surfaces and all non-removed appurtenances thereto can be mechanically cleaned and are easily accessible and easily removable for inspection</p>
<p><b>5.2.18 Insulation</b></p> <p>The insulation material shall be properly mounted and completely sealed to prevent the ingress of contaminants (e.g., moisture, pests).</p> <p>Insulation should be of a closed cell nature to prevent moisture ingress.</p>	<p><b>5.2.18 Insulation</b></p> <p>The insulation material shall be properly mounted and completely sealed to prevent the ingress of contaminants (e.g., moisture, pests).</p> <p>Insulation should be of a closed cell nature to prevent moisture ingress.</p>	<p><b>5.2.18 Insulation</b></p> <p>The insulation material shall be properly mounted and completely sealed to prevent the ingress of contaminants (e.g., moisture, pests).</p>
<p><b>5.2.19 SUPPORTS</b></p>		

A	B	C
<b>High Hygiene - Wet clean</b>	<b>High Hygiene - Dry clean</b>	<b>Basic Hygiene - Dry clean</b>
<p><b>5.2.19.1</b> Supports (e.g., legs) are to be smooth with rounded ends or with flat, load bearing feet suitable for sealing to the floor and have no exposed threads.</p> <p>Sufficient clearance around and under the equipment for cleaning and inspection shall be provided (see figure B.13).</p>	<p><b>5.2.19.1</b> Supports (e.g., legs) are to be smooth with rounded ends or with flat, load bearing feet suitable for sealing to the floor and have no exposed threads.</p> <p>Sufficient clearance around and under the equipment for cleaning and inspection shall be provided (see figure B.13).</p>	<p><b>5.2.19.1</b> Supports (e.g., legs) are to be smooth with rounded ends or with flat, load bearing feet suitable for sealing to the floor.</p> <p>Sufficient clearance around and under the equipment for cleaning and inspection shall be provided (see figure B.13).</p>
<p><b>5.2.19.2</b> Where casters are used, they shall be of sufficient size to provide sufficient clearance between the lowest part of the base and the floor for easy cleaning and inspection. Casters shall be easily cleanable, durable, and of a size that permits easy movement of the equipment.</p>		
<p><b>5.2.19.3</b> Where the equipment is to be floor or wall mounted, supports shall be designed for sealing to the mounting space or sufficient clearance around and under the equipment for cleaning and inspection shall be provided (see figure B.13).</p>		
<p><b>5.2.20 Product contact with equipment fluids</b></p> <p>Equipment shall be designed, fabricated, and installed to prevent the ingress of unwanted fluids (e.g., lubricating and hydraulic fluids, signal transfer liquids) into the product</p>		
<p><b>5.3 Criteria for specific equipment</b></p>		
<p><b>5.3.1 Nameplates</b></p> <p>Company name or information plates shall be fully bonded to the unit. Welding of metal plates are preferred. However, plates may be bonded with a suitable adhesive or be sealed.</p> <p>Alternative method would be to mount nameplate with standoffs so area behind can be cleaned adequately.</p>		
<p><b>5.3.2 Pneumatic equipment</b></p> <p>Exhaust air shall be piped below and away from product surface areas.</p>		
<p><b>3.3 Equipment that uses a single pass water flush</b></p> <p>Equipment that uses a single pass water flush shall have a drain that directs water to a non-product contact area or to a proper connection to a drainage system.</p>	<b>NOT APPLICABLE</b>	<b>NOT APPLICABLE</b>

<b>A</b>	<b>B</b>	<b>C</b>
<b>High Hygiene - Wet clean</b>	<b>High Hygiene - Dry clean</b>	<b>Basic Hygiene - Dry clean</b>
<p><b>5.3.4 Belts</b></p> <p>The use of belts with fabric carcasses or substrate materials should be avoided, but where unavoidable the edges shall be sealed with an acceptable compound.</p>	<p><b>5.3.4 Belts</b></p> <p>The use of belts with fabric carcasses or substrate materials should be avoided, but where unavoidable the edges shall be sealed with an acceptable compound.</p>	<p><b>5.3.4 Belts</b></p> <p>Belt selection shall be based on a risk assessment for the application and product.</p>
<p><b>5.3.5 Spraying devices</b></p> <p>Radii on spraying devices may be less than 1/32 in (0.031 in, 0.79 mm). When radii are less than 1/32 in (0.031 in, 0.79 mm), the internal angles must be cleanable and inspectable.</p> <p>There shall be no exposed threads or crevices on product contact surfaces of high and low pressure spraying devices except where required for functionality and safety reasons.</p>	<b>NOT APPLICABLE</b>	<b>NOT APPLICABLE</b>

**ANNEX B**  
**EXAMPLES FROM NSF/ANSI/3A 14159-1**

**FIGURE B.1 – DRAINAGE OF VESSELS**

Figures B.1 to B.14 are examples of a particular problem with the objective of enhancing and illustrating the text of Sections 5 and 6. In many cases, alternative solutions, which are equally as hygienic, could be found. Poor examples of hygienic design are illustrated on the left hand side of the page (hygiene risk) and good examples on the right hand side (acceptable).

**Hygiene risk**

**Acceptable**

Not drainable design

Drainable design

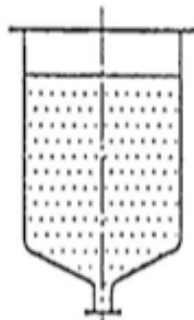
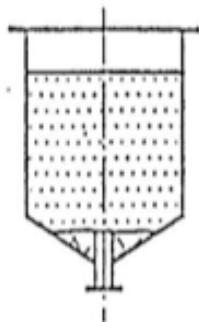
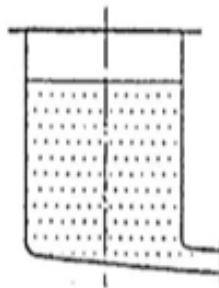
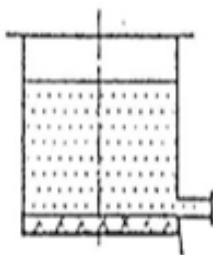
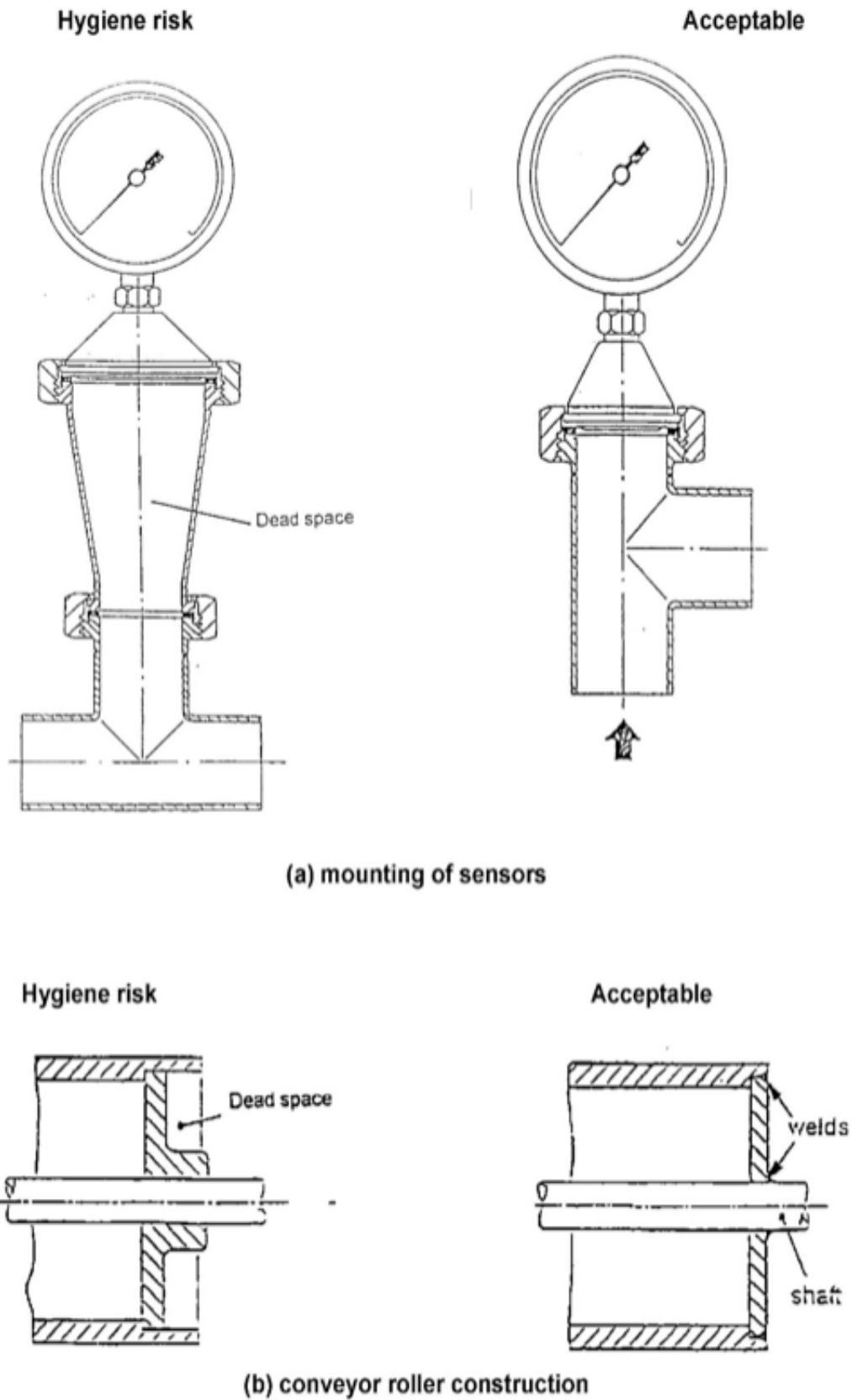
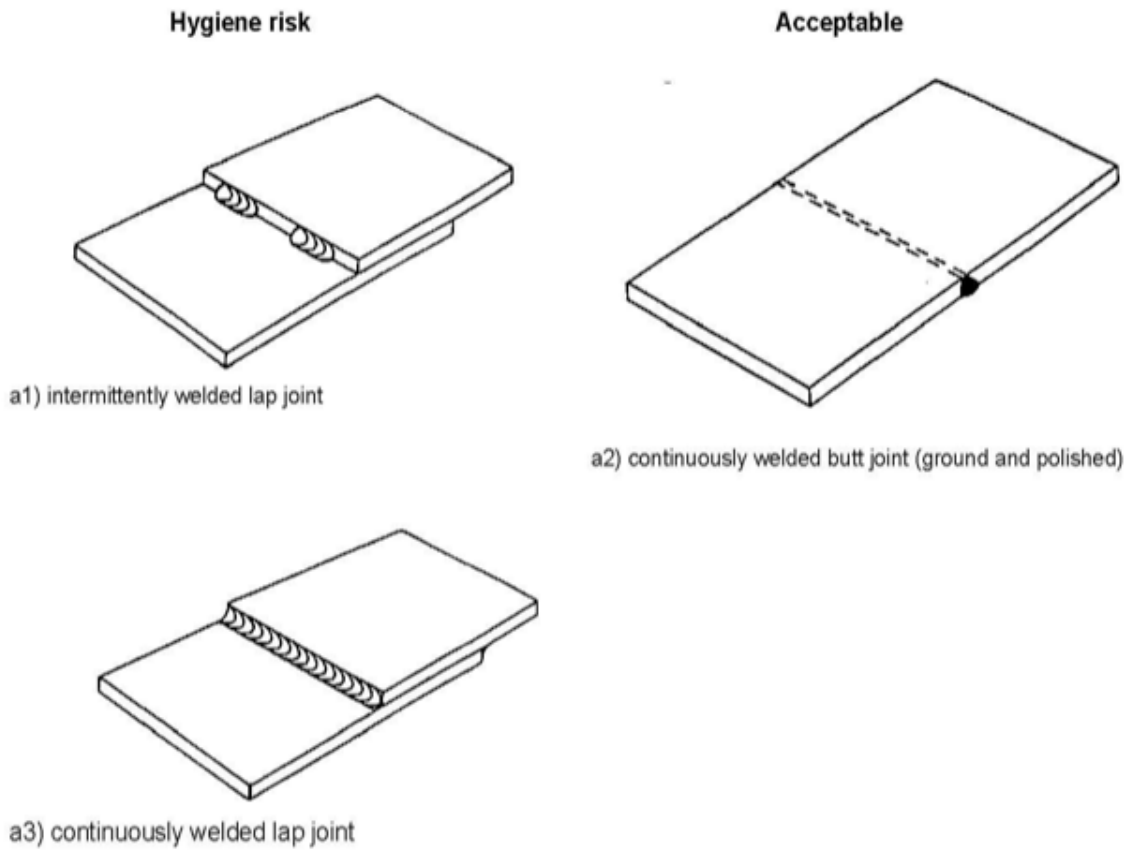

FIGURE B.3 – DEAD SPACES



**FIGURE B.4 – PERMANENT JOINTS**



(a) welded joints

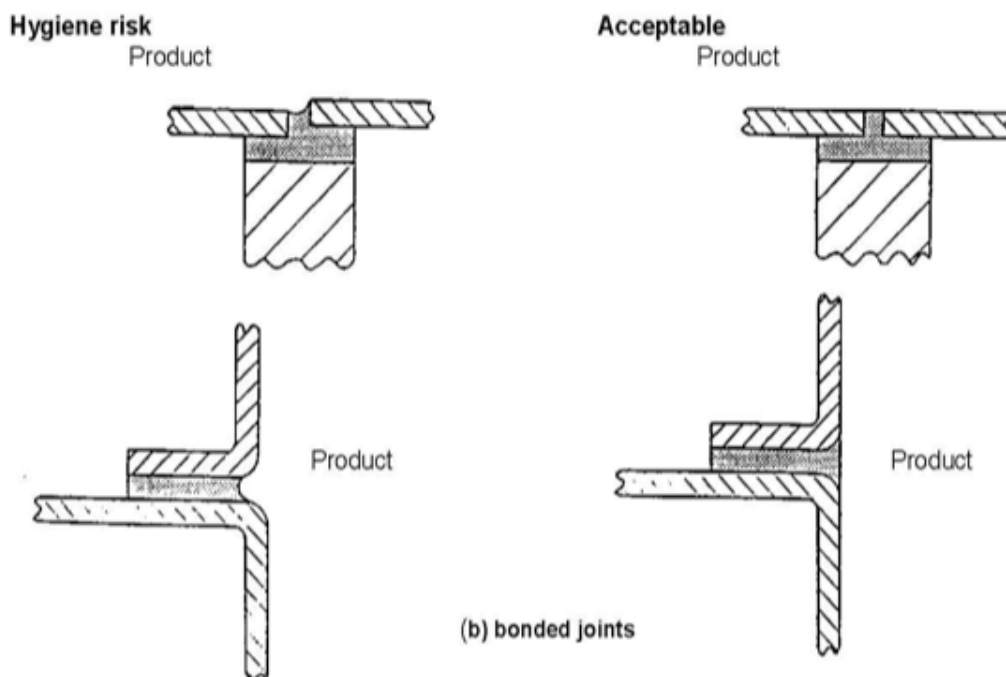

(b) bonded joints

FIGURE B.5 – DISMOUNTABLE JOINTS

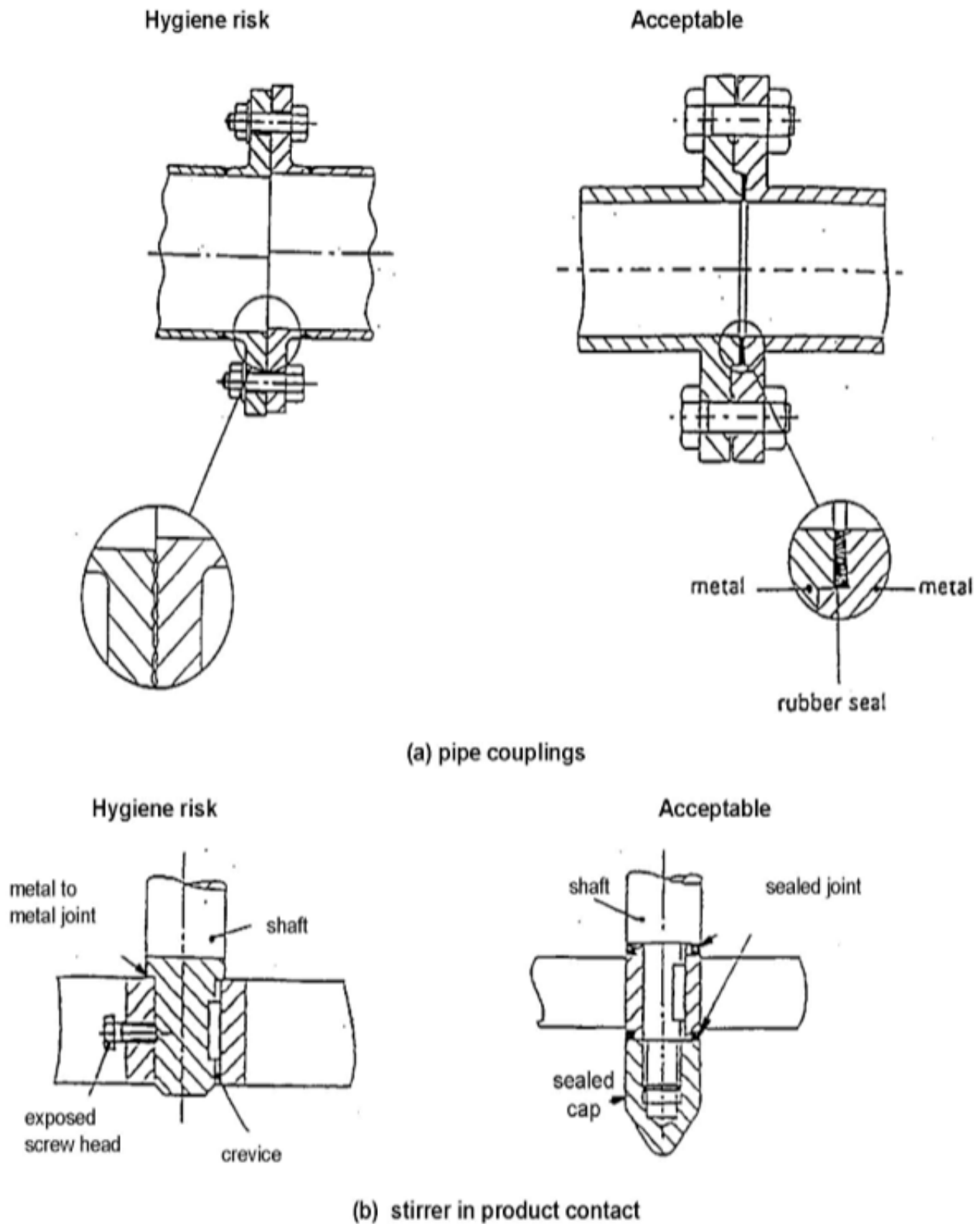

**FIGURE B.7 – CONTROLLED COMPRESSION AND THERMAL EXPANSION OF ELASTOMERS**

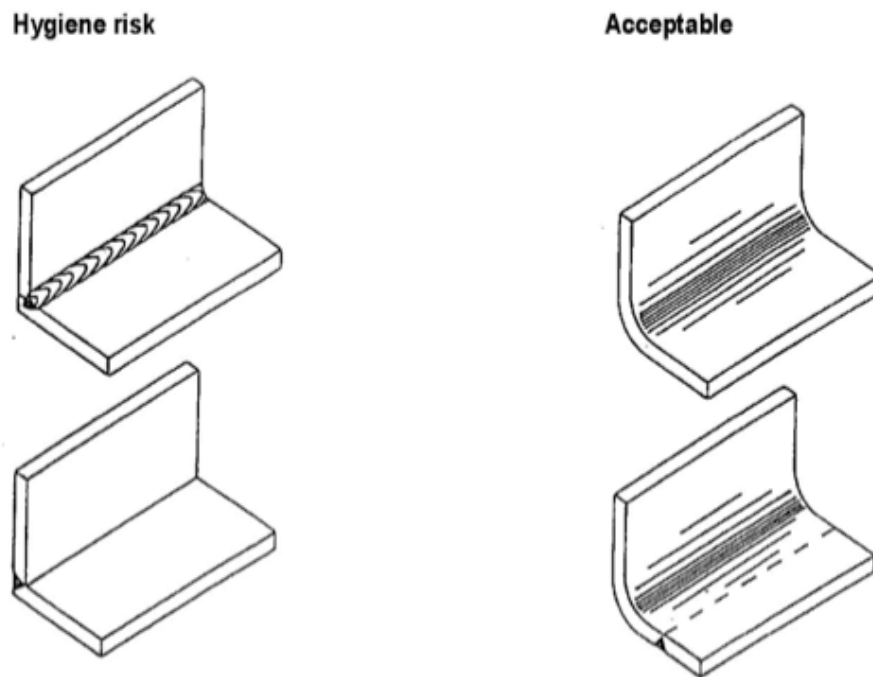

**Figure B.6 – Internal angles and corners**

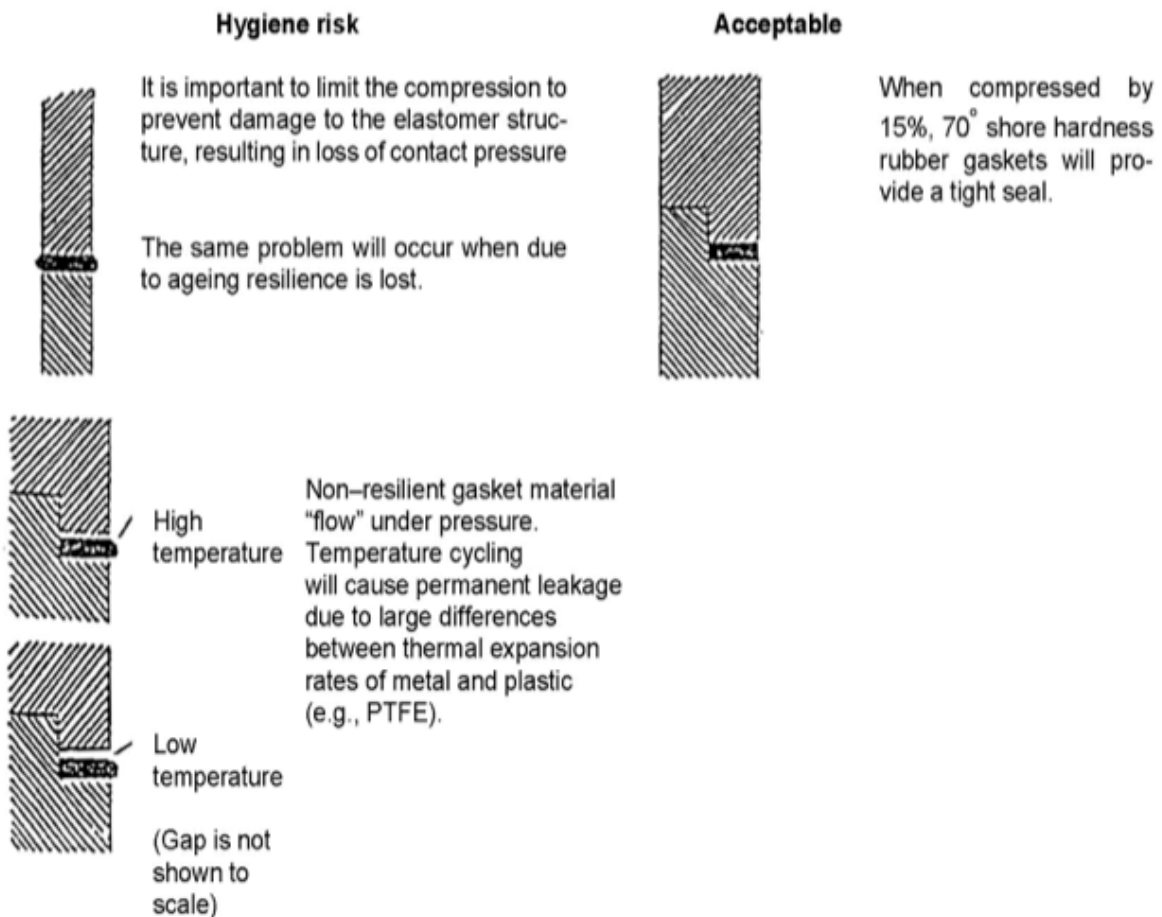
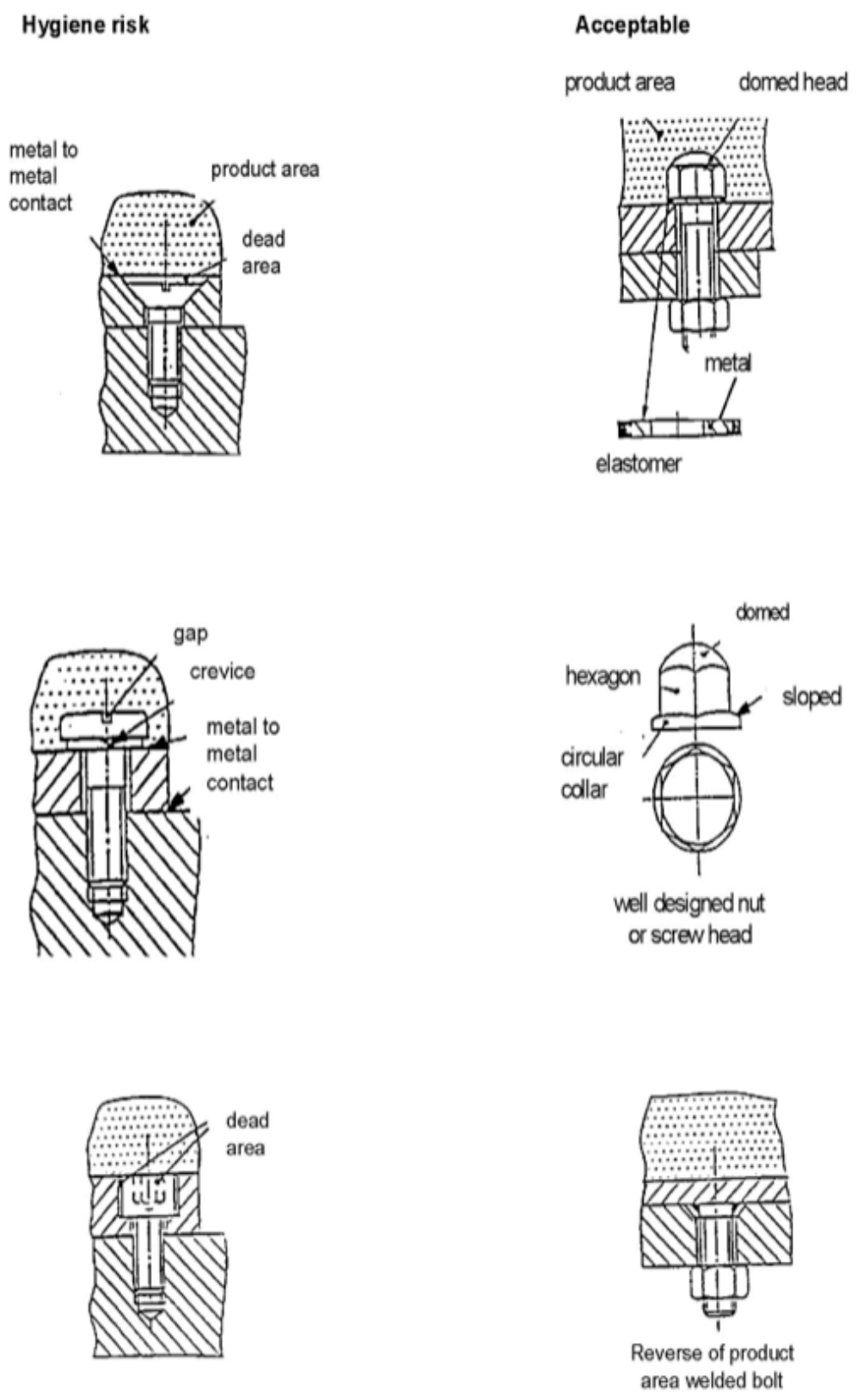

FIGURE B.8- DESIGN OF FASTENERS



**FIGURE B.10 – PRODUCT LUBRICATED BEARINGS**

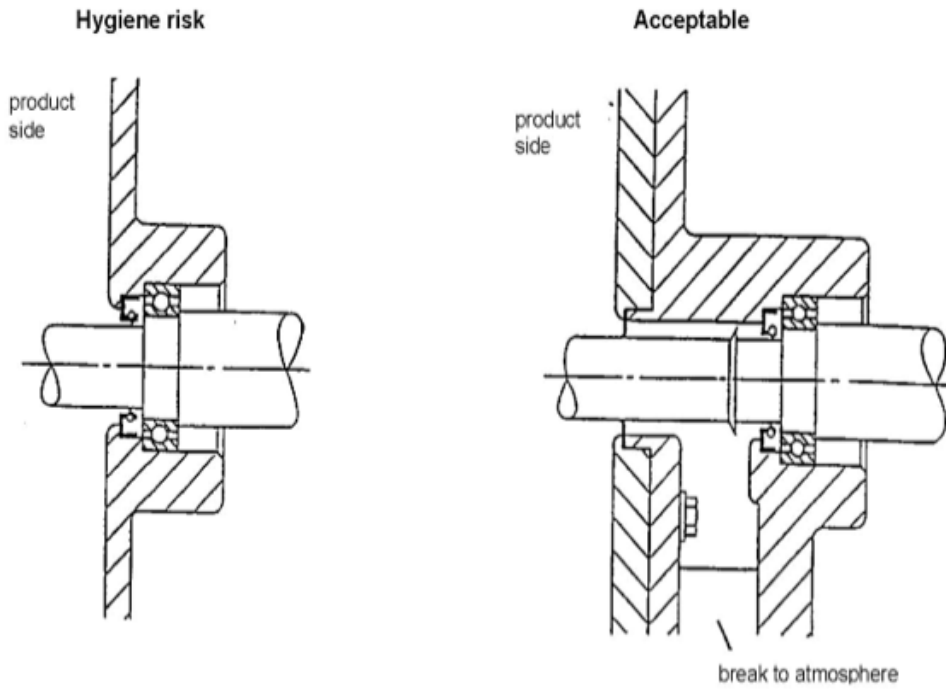

Figure B.9 – Shaft entry design

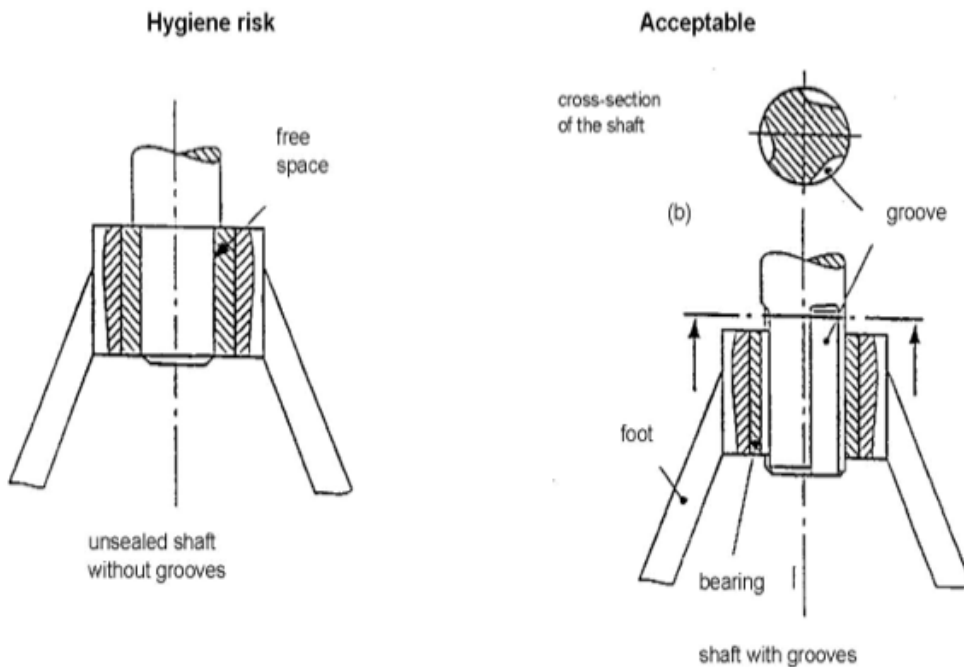

FIGURE FIGURES B11 AND B12 – FRAMEWORK (SUPPORTS)

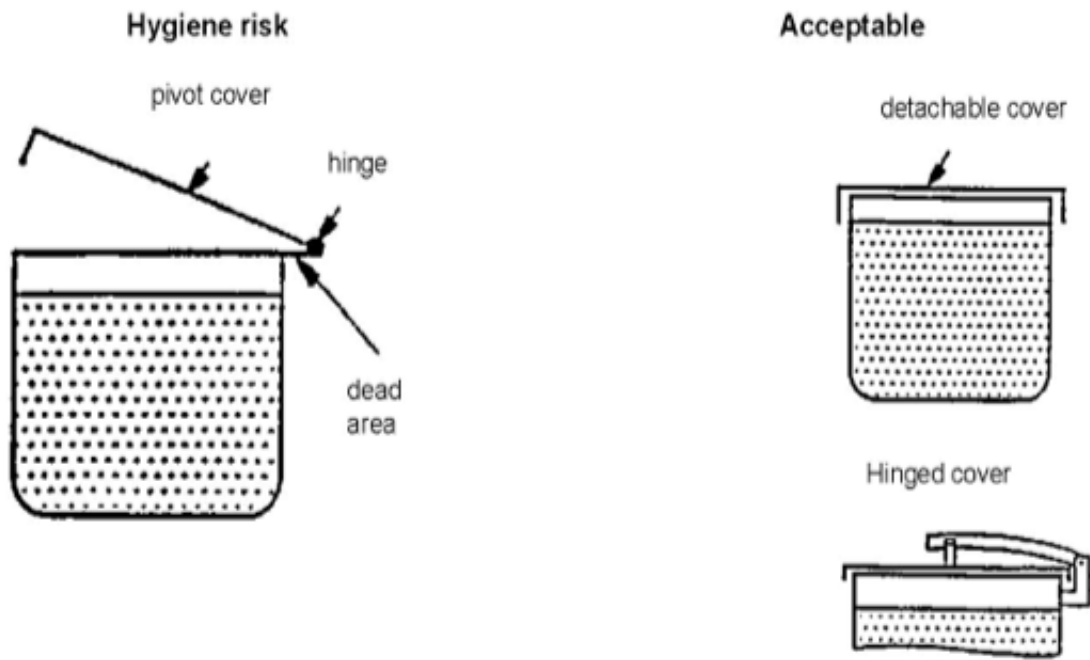
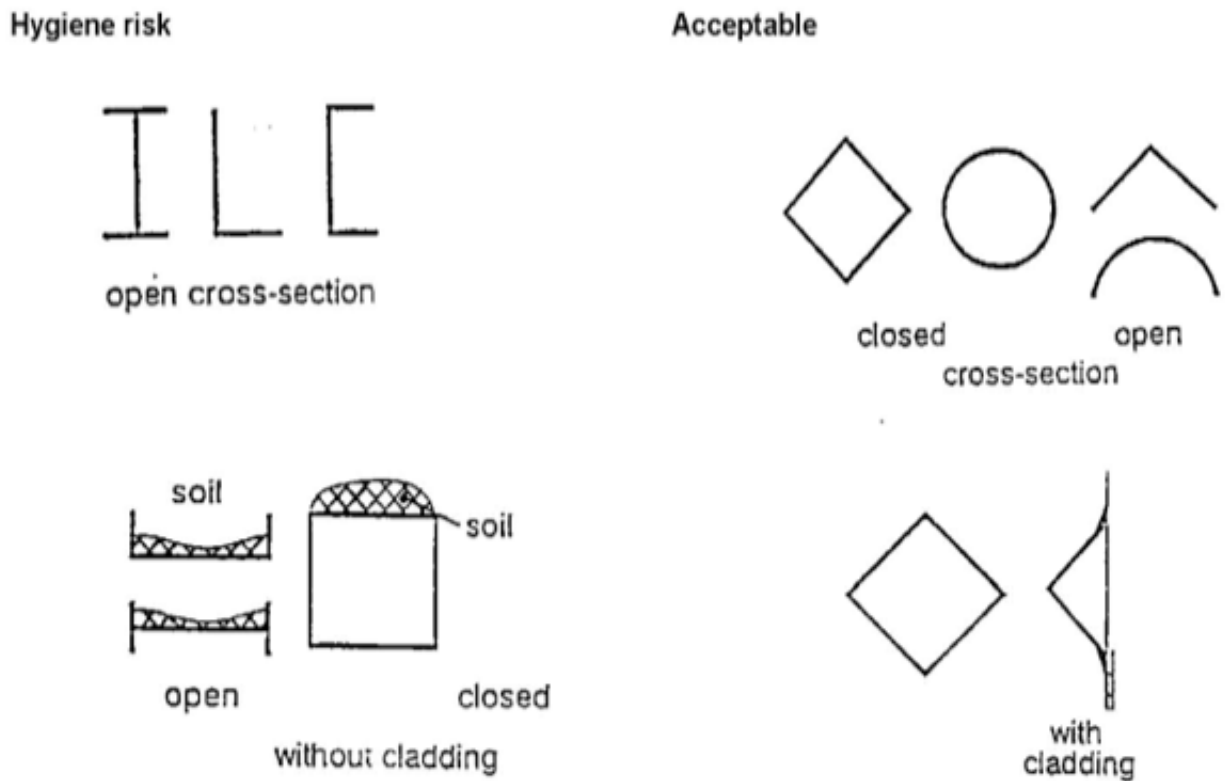
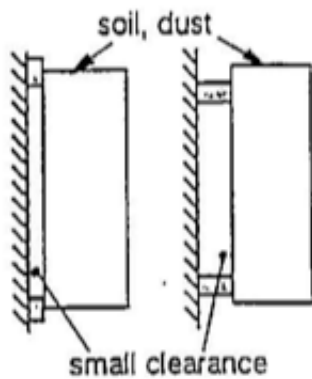
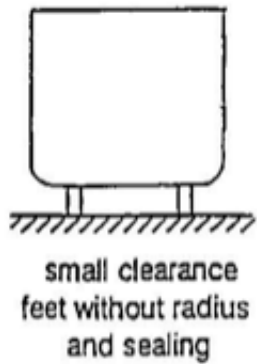

Figure B.11 – Openings and covers



FIGURES B13 AND B14- ACCESSIBILITY OF EQUIPMENT

Hygiene risk



Acceptable

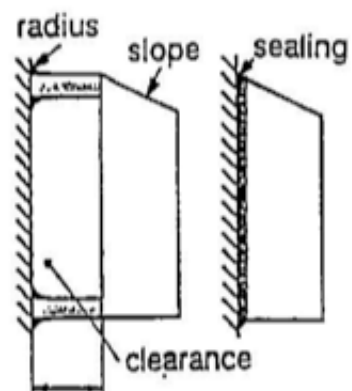
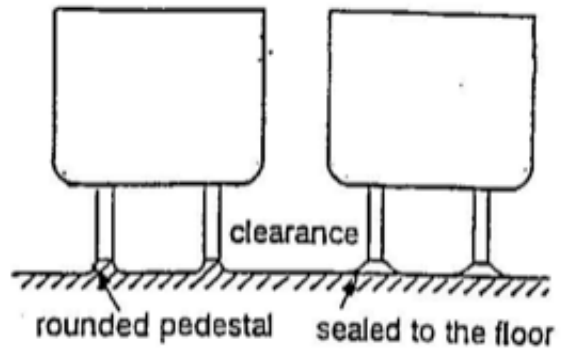
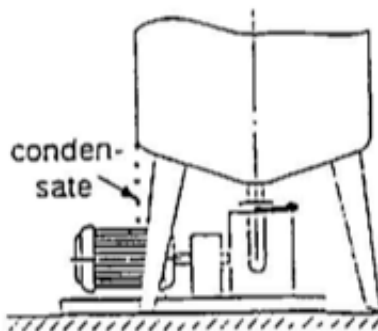
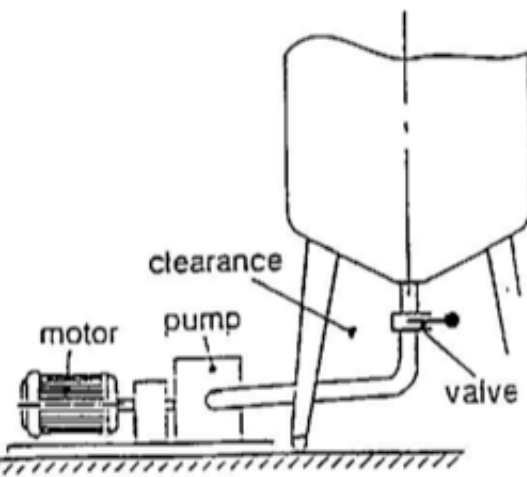

Figure B.13 – Floor and wall mountings

Hygiene risk



Acceptable





The Association for Packaging  
and Processing Technologies



Copyright © 2016. PMMI. This publication was developed through the OpX Leadership Network, convened by PMMI. It may be downloaded, reproduced, and distributed for business or academic use, but not for license or sale, provided there is clear attribution to the OpX Leadership Network as the developer of the publication and PMMI as the copyright owner.